



# V8

## USER'S MANUAL

IGS Audio Igor Sobczyk  
3 Maja 76d, 41-400 Mysłowice, Poland  
e-mail: [igs@o2.pl](mailto:igs@o2.pl) ph: +48 601 597 592

[www.igsaudio.com](http://www.igsaudio.com)

Please read all of the following instructions and save them for later reference before attempting to connect the unit to the mains.

#### EARTH

This unit is connected via its power cord to the mains safety earth.  
**NEVER OPERATE THE UNIT WITH THIS EARTH CONNECTION REMOVED.**

#### COVERS

**DO NOT** remove the covers. Refer servicing to qualified personnel only.

#### VOLTAGE

Equipment is set to operate only at the voltage indicated on the back of the unit.  
**CHECK** that the correct voltage is selected before connecting the AC mains supply.

#### FUSES

**CHECK** that the fuse fitted is the correct type for the local mains voltage.  
**ALWAYS** replace fuse with the correct type.

#### MOISTURE

**DO NOT** expose the unit to rain or moisture. If the unit should become so exposed **REMOVE** the mains power immediately.

#### CABLES

**PROTECT** the mains power cord from damage though impact or abrasion.

#### HEAT

**ALWAYS** site the unit away from sources of heat including direct sunlight and ensure adequate ventilation around the unit.

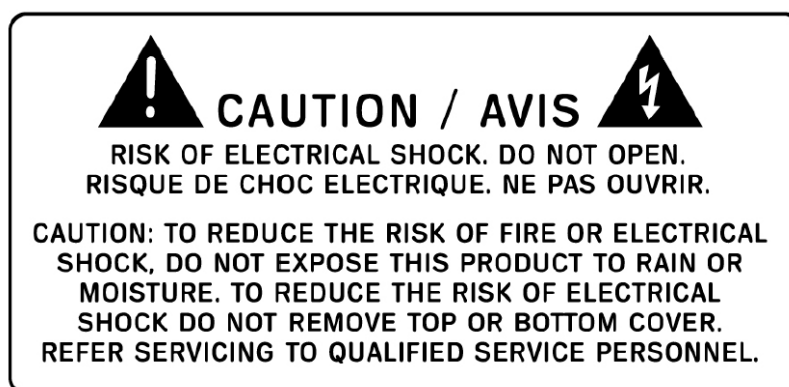

Copyright 2014. All rights reserved.

The information in this document is subject to change without notice.

IGS Audio makes no warranty of any kind with respect to the material in this document and shall not be liable for errors contained herein or for incidental or consequential damages related to the use of the material.

Manual revision: 1.0 (December 2014)



**Thank you for buying this IGS Audio product.**

Please read the information provided below very carefully before using your IGS unit.

**Unpacking**

Your V8 has been carefully and meticulously tested and inspected before dispatch. Please check for any signs of transit damage. If any signs of mishandling are found please notify the carrier and your dealer immediately.

Your V8 packing should contain an V8 with IGS Audio tag and power cord and this manual with the Warranty and RoHS/CE/WEEE Declaration attached.

**Compatibility and Power**

There is a fuse socket near the power cable connector on the on the back of the unit. Ensure that the correct fuse is being used before plugging the V8 to the power outlet.

- For US area (115V) use 630mA Slow Blow (Type T).
- For Europe and rest of the world area (230V) use 315mA Slow Blow (Type T).

**Always check the voltage selector on the back of the unit** to ensure that it is set to the proper voltage available in your country.

## IGS AUDIO V8 – Stereo compressor

The V8 compressor is built solely with discrete components and six Carnhill transformers (three per channel). The element responsible for the compression is the bridge composed of 4 pulse diodes matched by hand, according to carefully developed procedures. The device is constructed as a dual mono unit with the option of linking the sidechain circuitry. All manipulators are stepped, for excellent channel matching. The V8 compressor is also equipped with a sidechain HPF. This feature allows you to cut the lowest frequencies off from the signal, before it hits the sidechain stage and allow, for example the kick drum, to go thru without the pumping effect. An additional switch on the front (+10THR) lowers the compressor's threshold level by an extra 10dB. This feature is useful when compressing very low signals or for very strong compression. The typical application for IGS V8 is mix buss compression. However, due to its nature and the incredible range of tone and color settings, the use of the V8 compressor is unlimited.

It is this compressor that I would want to have on a desert island :) The V8 takes its name from the order of projects. This is the eighth compressor that IGS Audio offers.

### Block diagram

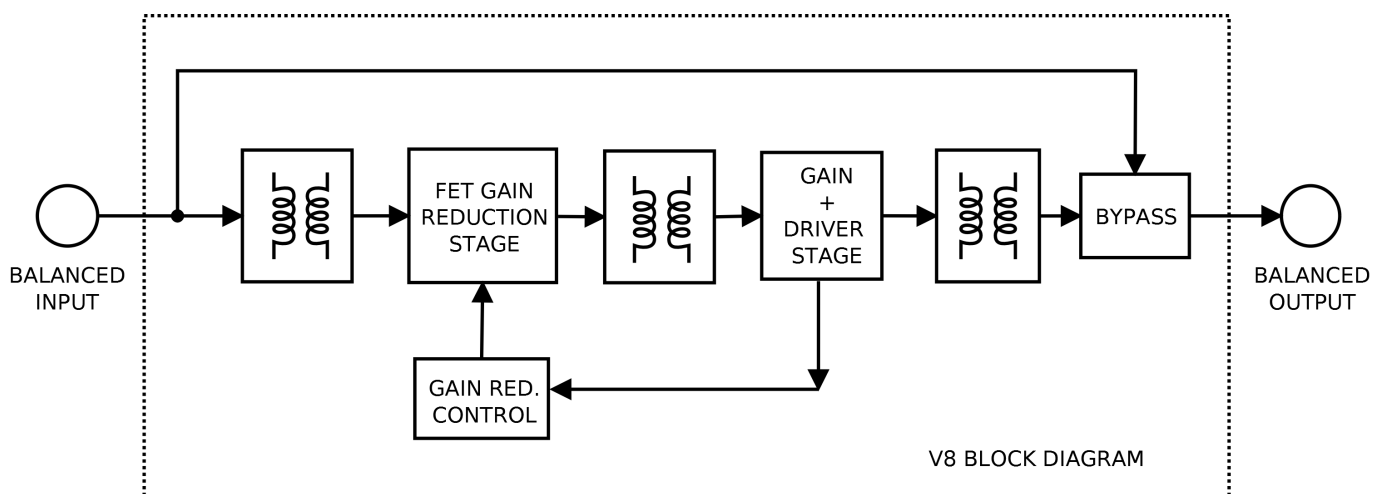

**THRESHOLD      RATIO      RELEASE      OUTPUT      GR METER**



**ATTACK      HPF ON/OFF      HPF FREQ      BYPASS      LINK ON/OFF**

**GR METER** Big VU meter showing the amount of gain reduction applied

**THRESHOLD** Above this level of the input signal the compression will occur. Use it to control the amount of compression.

**RATIO** Allows to adjust the compressor ratio. From 1,2:1 (soft compression) up to 10:1.

**ATTACK** Time delay between the appearance of the signal and the compressor reaction.

**RELEASE** Time delay between the disappearance of the signal and the compressor reaction.

**+10dB THRESHOLD** Lowers the threshold level by 10dB. Allows to use heavy and deep compression.

**BYPASS** The audio signal passes thru the compressor circuit when this switch is set to „IN”. The „BYPASS” setting causes the circuit to be taken off the signal path.

**OUTPUT** Output level knob.

**HPF ON/OFF** This switch applies the high pass filtering to the sidechain circuit. It allows to avoid the „pumping” sound, ie. the kick drum – low frequencies will not trigger the compressor.

**HPF FREQ** Frequency selector for sidechain high pass filter

**LINK ON/OFF** Channel Link – When set to ON the higher sidechain signal will control the compression on both channels

**V8 technical specification:**

- 6 Carnhill transformers
- A-class design
- two linkable channels

Operating Level	+4dBu
Maximum Input	+16dBu
Maximum Output	+18dBu
Input impedance	600 ohm
Output Impedance	600 ohm
Transformers	6 x Carnhill
Max Gain Reduction	30
Maximum Gain	22
Attack Time	0.1 – 30 ms
Release Time	0.1 to 1,4s + auto
Frequency response	20Hz - 20kHz
THD+N @0dBu	85 dB (A)
Power consumption	40 W
Shipping weight	7kg
Dimensions	19" 2U, 230mm deep

## **Troubleshooting**

### **My unit doesn't light up (the VU meter is dark):**

- Please check the power cord and the switch at the front of the unit is in ON position
- Check the fuses

### **The signal plays thru but there is no change in signal when i turn the knobs:**

- Please check the bypass switch

### **No signal plays thru the unit, regardless the settings at the front panel:**

- Please check the cables connecting the rack.

### Warranty:

**This device is declared to be free from defects in material and workmanship for a period of three years. Any device found defective within three years from the delivery date and returned to the factory, will be repaired, adjusted, or replaced and sent to the customer with no charge. The customer always pays the shipping cost to us. This warranty does not cover expendable items such as tubes or fuses. If the defect has been caused by a misuse or abnormal operation conditions, the repair will be billed at a nominal cost. The product should be returned in its original package, if this is possible, or packed in such a way that it is not damaged during the shipment. We are not to be held responsible for any damages during the shipment. 19" units shall always be packed in a box with support for the rack ears. All 500 series modules need to be secured in ESD bag and protected with foam. We will charge the customer €20 + VAT if the packing material needs to be replaced. If we find that the product works perfectly, the customer will be invoiced €50 + VAT to cover our costs of examination and handling plus the cost for returning the product to the customer.**

