

# STX815M 15" Two-Way, Stage Monitor/ Utility Speaker

## Professional Series

### Key Features:

- ▶ Premium passive loudspeaker system
- ▶ Very high power handling
- ▶ 70° x 70° coverage
- ▶ Bi-amplified or full-range passive operation
- ▶ Pole socket for applications requiring tripod mounting
- ▶ Twelve M10 suspension points
- ▶ Vented Gap Cooled™ woofer for high power capacity
- ▶ 3" (voice-coil) compression driver with neodymium magnet

### Applications

- ▶ Reinforcement of music and speech in entertainment or AV applications
- ▶ High-performance satellite speaker for use with subwoofers

The STX815M is high-power, light-weight two-way loudspeaker system offering the highest level of performance available from a speaker that can be placed on a pole or standard speaker tripod stand. The STX815M is comprised of a 380 mm (15 in) 2226H patented Vented Gap Cooled™ woofer which handles 800 watts (continuous) yet the entire system weighs only 26 kg (58 lb). For high frequencies, a 2432H 75 mm (3 in) voice-coil, neodymium compression driver is mounted to a 70° by 70° horn.

Bi-amp or full-range passive operation may be selected by means of a recessed, high-current switch mounted on the input plate.

For applications requiring suspension, the enclosure is fitted with twelve M10 suspension points as well as a 35 mm pole mount.

The enclosure is constructed of top quality birch/poplar laminate plywood and coated in JBL's rugged DuraFlex™ finish. The attractive CNC-machined, 14-gauge steel grille wraps around the sides of the enclosure so there are no protruding lips on the front of the box to create acoustical interference. The grilles are internally lined with acoustically transparent foam to provide additional driver protection and give a very professional appearance.



With STX818S and SS4-BK

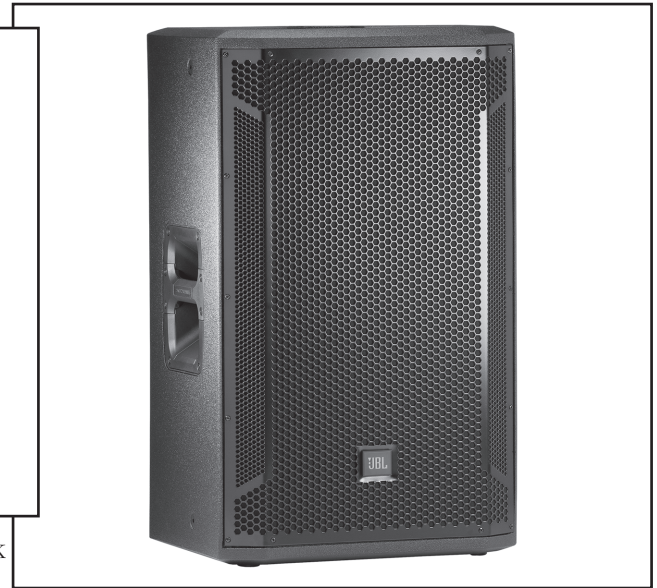

### Specifications:

|   |  |
|---|--|
| Frequency Range (-10 dB):                                   | 41 Hz – 20 kHz   |
| Frequency Response (±3 dB):                                 | 55 Hz – 20 kHz   |
| Coverage Pattern:   | 70° x 70° nominal  |
| Crossover Modes:  | Bi-amp / passive, externally switchable  |
| Crossover Frequency:  | 1.8 kHz  |
| Power Rating<br>(Continuous <sup>1</sup> / Program / Peak): | Passive: 800 W / 1600 W / 3200 W<br>Bi-amp LF: 800 W / 1600 W / 3200 W<br>Bi-amp HF: 75 W / 150 W / 300 W            |
| Maximum SPL <sup>2</sup> :                                  | 131 dB SPL peak  |
| System Sensitivity (1w @ 1m):                               | 96 dB SPL (passive mode)   |
| LF Driver:  | 1 x JBL 2226H 380 mm (15 in) Vented Gap Cooled™ woofer   |
| HF Driver:  | 1 x JBL 2432H 75 mm (3 in) voice-coil, neodymium-magnet compression driver   |
| Nominal Impedance:  | Passive: 8 ohms<br>Bi-amp LF: 8 ohms<br>Bi-amp HF: 8 ohms  |
| Active Tunings:   | Designed for Crown and dbx DriveRack. Settings available at <a href="http://www.jblpro.com">www.jblpro.com</a>       |
| Enclosure:  | Asymmetrical, 18 mm, 13-ply birch/poplar laminate plywood  |
| Suspension / Mounting:                                      | 35 mm pole socket<br>12 x suspension points, M10   |
| Transport:  | 2 side handles   |
| Finish:   | Black DuraFlex finish  |
| Grille:   | Powder coated, black, 14-gauge perforated steel with acoustical transparent charcoal foam backing.                   |
| Input Connectors:   | Neutrik® Speakon® NL-4 (x2)  |
| Dimensions (H x W x D):                                     | 721 mm x 436 mm x 329 mm<br>(28.4 in x 17.2 in x 13.0 in)  |
| Net Weight:   | 26 kg (58 lb)  |
| Optional Accessories:                                       | 229-00009-01: 3 x 10 mm forged eyebolt kit<br>For covers, go to <a href="http://www.jblbags.com">www.jblbags.com</a> |

<sup>1</sup>IEC filtered noise with 6 dB crest factor, 2 hour duration.  
<sup>2</sup>Calculated based on peak power rating and sensitivity, 1 m.

JBL continually engages in research related to product improvement. Some materials, production methods and design refinements are introduced into existing products without notice as a routine expression of that philosophy. For this reason, any current JBL product may differ in some respect from its published description, but will always equal or exceed the original design specifications unless otherwise stated.

# STX815M 15" Two-Way Stage Monitor/Utility Speaker

## Block Diagram

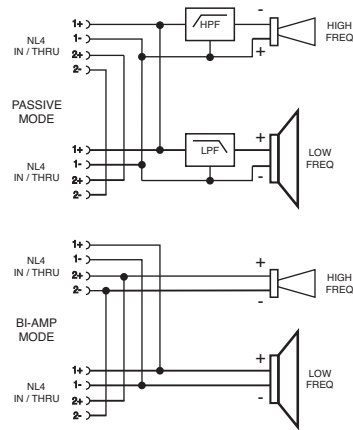

## Frequency Response and Impedance

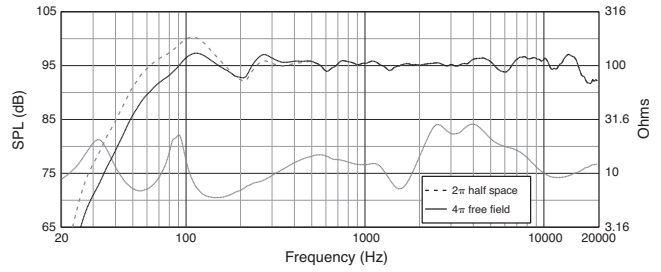

## Beamwidth

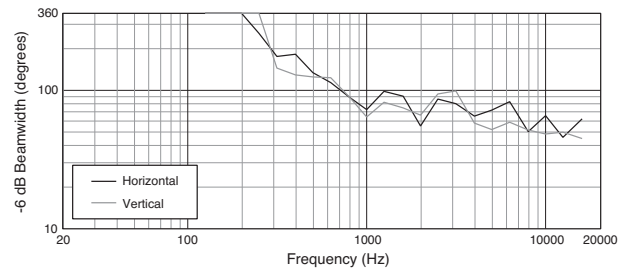

## Directivity Index, Q

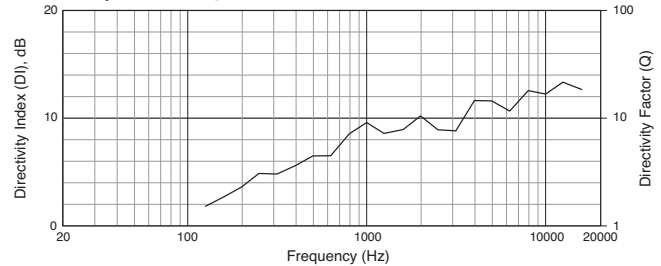

Measurements obtained in full passive crossover mode with no signal processing. Graphs are from unaltered measured data.

## Dimensions

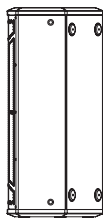
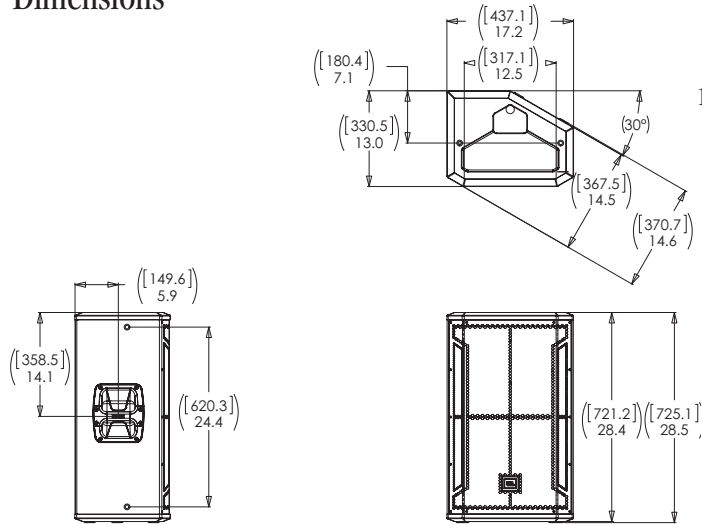

JBL Professional  
 8500 Balboa Boulevard, P.O. Box 2200  
 Northridge, California 91329 U.S.A.

© Copyright 2012 JBL Professional  
[www.jblpro.com](http://www.jblpro.com)

SS STX815M  
 CRP  
 06/12 A