



User's Guide

DR 500 series



Antes de utilizar el equipo, lea la sección "Precauciones de seguridad" de este manual. Conserve este manual para futuras consultas.

Before operating the device, please read the "Safety precautions" section of this manual. Retain this manual for future reference.

CONTENTS

SAFETY PRECAUTIONS	3
WARRANTY	4
DECLARATION OF CONFORMITY	5
INTRODUCTION	6
CONFIGURATIONS	7 a 10
<u>2 x DR-515 (o DR-512)</u>	
<u>2 x DR-515 / DR-508 / DR-512 + action18</u>	
<u>2 x DR-515 (o DR-512) + 2 x action18</u>	
<u>2 x DR-515 (o DR-512) + 2 x action218</u>	
RIGGING SYSTEM	11 a 13
LINE DRAWINGS	14
SPECIFICATIONS	15

DR-500 series

Precauciones de Seguridad Safety Precautions



Cajas acústicas pasivas / Passive loudspeaker enclosures

Conserve y lea todas estas instrucciones.

Siga todas las advertencias.

El signo de exclamación dentro de un triángulo indica la existencia de componentes internos cuyo reemplazo puede afectar a la seguridad.



Keep these instructions.

Heed all warnings. Follow all instructions.

The exclamation point inside an equilateral triangle indicates the existence of internal components whose substitution may affect safety.

El doble cuadrado indica equipo de Clase II.



The double square indicates Class II device.

Las especificaciones se encuentran en la etiqueta de la parte posterior del producto.

The specifications can be found on the rear label of the product.

El colgado del equipo sólo debe realizarse utilizando los herrajes de colgado recomendados y por personal cualificado. No cuelgue la caja de las asas.

The appliance should be flown only from the rigging points and by qualified personnel. Do not suspend the box from the handles.

No exponga este equipo a la lluvia o humedad. No exponga el equipo a salpicaduras ni coloque sobre él objetos que contengan líquidos, tales como vasos y botellas. Equipo IP-20.

Do not expose this device to rain or moisture. Do not place any objects containing liquids, such as bottles or glasses, on the top of the unit. Do not splash liquids on the unit. IP-20 equipment.

Este símbolo indica que el presente producto no puede ser tratado como residuo doméstico normal, sino que debe entregarse en el correspondiente punto de recogida de equipos eléctricos y electrónicos.



This symbol on the product indicates that this product should not be treated as household waste. Instead it shall be handed over to the applicable collection point for the recycling of electrical and electronic equipment.

Equipo diseñado para funcionar entre 15°C y 42°C con una humedad relativa máxima del 95%.

Working temperature ranges from 15°C to 42°C with a relative humidity of 95%.

El cableado exterior conectado al equipo requiere de su instalación por una persona instruida o el uso de cables flexibles ya preparados.

The outer wiring connected to the device requires installation by an instructed person or the use of a flexible cable already prepared.

El equipo cuenta con dos conectores de entrada en paralelo para facilitar la conexión de varias cajas en paralelo.

Note that the two Speakon input connectors are wired in parallel to provide easy parallel connection of several enclosures.

No emplace altavoces en proximidad a equipos sensibles a campos magnéticos, tales como monitores de televisión o material magnético de almacenamiento de datos.



Do not place loudspeakers in proximity to devices sensitive to magnetic fields such as television monitors or data storage magnetic material.

Para las cajas con vaso para trípode, la altura máxima de seguridad desde el suelo a la base de la caja montada sobre trípode modelo TRD-2, con pies a 55 cm del eje del trípode, es:

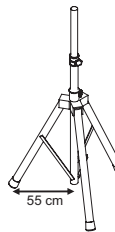

For enclosures with tripod socket, the maximum safety height from floor to bottom of enclosure when mounting on a TRD-2 tripod, with legs spread 55cm from the central pole, is:

DR-508----->150 cm

DR-512----->140 cm

DR-515----->130 cm

DR-508-----> 150 cm

DR-512----->140 cm

DR-515----->130 cm

No existen partes ajustables por el usuario en el interior de este equipo. Cualquier operación de mantenimiento o reparación debe ser realizada por personal cualificado. Es necesario el servicio técnico cuando el aparato se haya dañado de alguna forma, tal como que haya caído líquido o algún objeto en el interior del aparato, haya sido expuesto a lluvia o humedad, no funcione correctamente o haya recibido un golpe.

No user serviceable parts inside. Refer all servicing to qualified service personnel. Servicing is required when the apparatus has been damaged in any way, such as power-supply cord or plug is damaged, liquid has been spilled or objects have fallen into the apparatus, the apparatus has been exposed to rain or moisture, does not operate normally or has been dropped.

Limpie con un paño seco. No use limpiadores con disolventes.

Clean only with a dry cloth. Do not use any solvent based cleaners.

GARANTÍA

Todos nuestros productos están garantizados por un periodo de 24 meses desde la fecha de compra.

Las garantías sólo serán válidas si son por un defecto de fabricación y en ningún caso por un uso incorrecto del producto.

Las reparaciones en garantía pueden ser realizadas, exclusivamente, por el fabricante o el servicio de asistencia técnica autorizado.

Otros cargos como portes y seguros, son a cargo del comprador en todos los casos.

Para solicitar reparación en garantía es imprescindible que el producto no haya sido previamente manipulado e incluir una fotocopia de la factura de compra.

WARRANTY

All D.A.S. products are warrantied against any manufacturing defect for a period of 2 years from date of purchase.

The warranty excludes damage from incorrect use of the product.

All warranty repairs must be exclusively undertaken by the factory or any of its authorised service centers.

To claim a warranty repair, do not open or intend to repair the product.

Return the damaged unit, at shippers risk and freight prepaid, to the nearest service center with a copy of the purchase invoice.



DECLARACIÓN DE CONFORMIDAD DECLARATION OF CONFORMITY

D.A.S. Audio, S.A.

C/ Islas Baleares, 24 - 46988 - Pol. Fuente del Jarro - Valencia. España
(Spain).

Declara que la *serie DR-500*:

Declares that *DR-500 series*:

Cumple con los objetivos esenciales de las Directivas:

Abide by essential objectives relating Directives:

- Directiva de Baja Tensión (Low Voltage Directive) 2006/95/CE
- Directiva de Compatibilidad Electromagnética (EMC) 2004/108/CE
- Directiva RoHS 2011/65/CE
- Directiva RAEE (WEEE) 2002/96/CE

Y es conforme a las siguientes Normas Armonizadas Europeas:

In accordance with Harmonized European Norms:

- EN 60065:2002 / A11:2008
Audio, video and similar electronic apparatus. Safety requirements.
- EN 55103-1:2009
Electromagnetic compatibility. Product family standard for audio, video, audio-visual and entertainment lighting control apparatus for professional use. Part 1:Emission.
- EN 55103-2:2009
Electromagnetic compatibility. Product family standard for audio, video, audio-visual and entertainment lighting control apparatus for professional use. Part 2:Immunity.

INTRODUCTION

The *DR 500 series* combines design with function, achieving a product that redefines the meaning of reliability, sound quality and efficiency in compact sound reinforcement enclosures. The use of the latest high-pressure injection molding techniques provides the *DR 500 series* with structural polypropylene enclosures that are both attractive and durable. They are specially appropriate in any sound reinforcement application requiring a lightweight compact solution.

Características

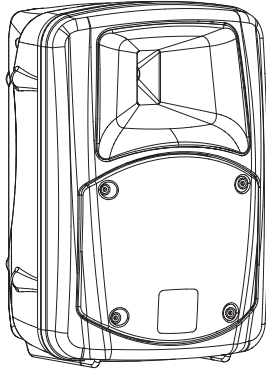

DR-508

- Compact 2-way, full-range system
- 8" bass loudspeaker
- Compression driver with titanium diaphragm
- Multiple mounting options
- Stand mountable

The *DR-508* is an ultracompact full-range system that uses a new 8" low frequency transducer. The *M-34* compression driver handles high frequency reproduction. The polypropylene enclosure is light-weight and rugged.

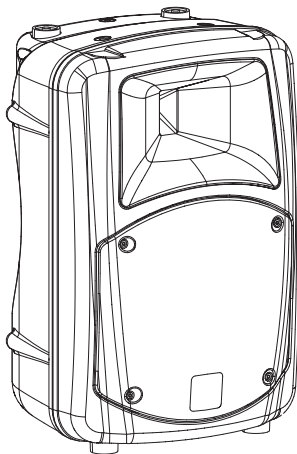

DR-512

- Compact 2-way, full-range system
- 12" bass loudspeaker
- Compression driver with titanium diaphragm
- Multiple mounting options
- Stand mountable

The *DR-512* combines design with function in a medium size enclosure. Its unique enclosure offers an oversized handle for easy carrying, will accept a standard 35 mm mounting stand and includes a floor monitor position for added flexibility. Built-in rigging points and an optional mounting bracket facilitates use in permanent installations. The 2-way passive design incorporates 12" low frequency transducer and the *M-34* compression driver.

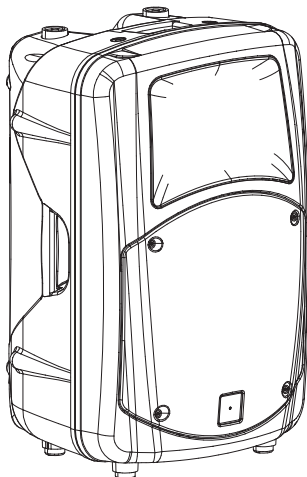

DR-515

- 2-way, full range system
- 15" bass loudspeaker
- Compression driver with titanium diaphragm
- Stand mountable
- Monitor position

The *DR-515* exemplifies the achievements of D.A.S. engineers in high pressure injection molding technology. The *DR-515* mounts a proprietary 15" low frequency transducer and the high efficiency *M-34* compression driver and CD horn assembly.

CONFIGURATIONS

Dr-515 (or DR-512)

Dr-515 (or DR-512)

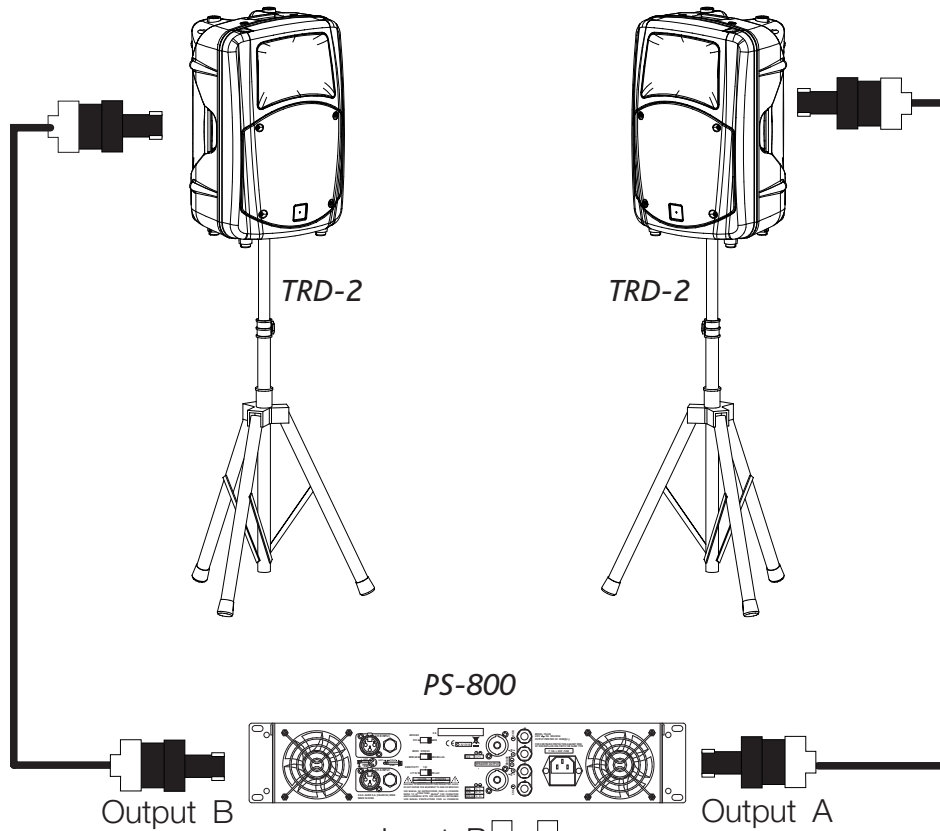

Input B Input A

DSP-26



L R

Mixer

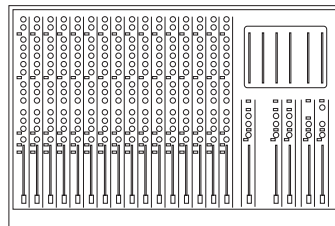

DR-515

DR 500 series

D.A.S. Audio, s.a. (Valencia) MADE IN SPAIN

PROGRAM POWER	700 W
RMS POWER	350 W
IMPEDANCE	8 Ω
FREQUENCY RANGE	47 Hz - 20 kHz

22000001

INPUT (+1 -1)

LINKED

DR-512

DR 500 series

D.A.S. Audio, s.a. (Valencia) MADE IN SPAIN

PROGRAM POWER	600 W
RMS POWER	300 W
IMPEDANCE	8 Ω
FREQUENCY RANGE	50 Hz - 20 kHz

22000001

INPUT (+1 -1)

LINKED

CONFIGURATIONS (cont'd)

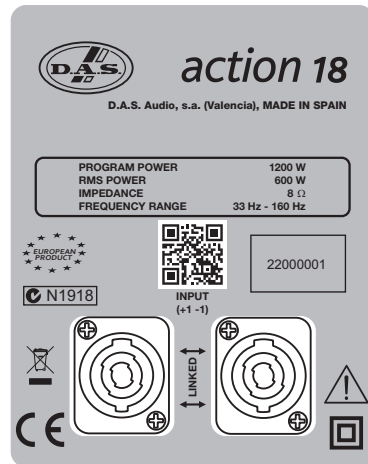
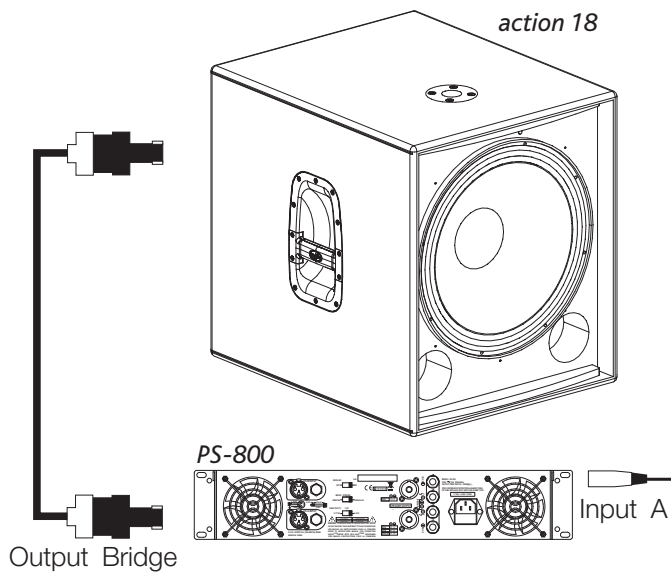

DR-508 / DR-512 / DR-515

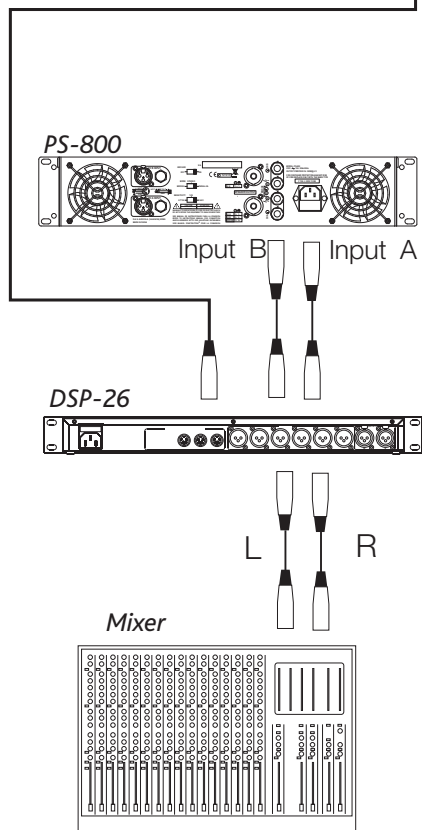
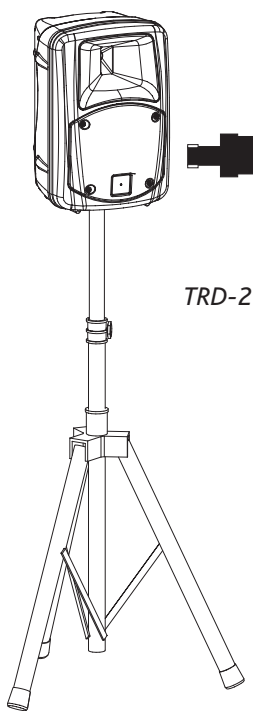

DR-508 / DR-512 / DR-515

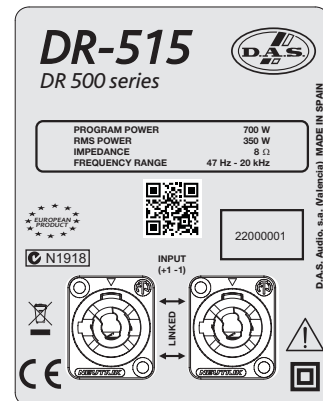
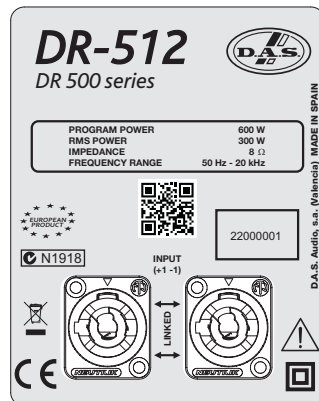
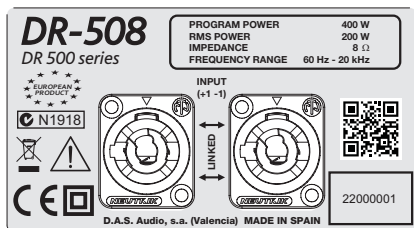
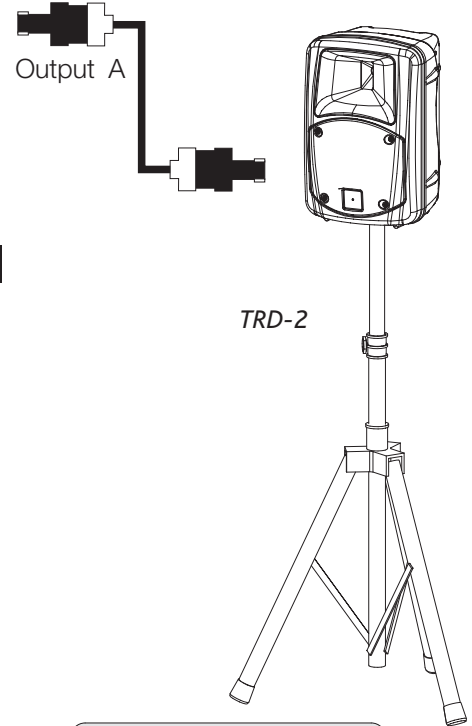

CONFIGURATIONS (cont'd)

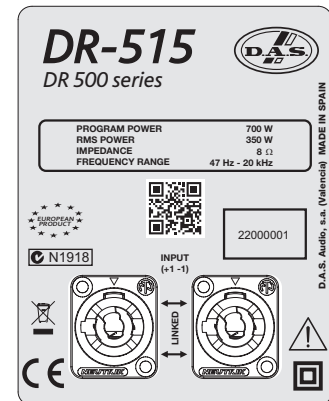
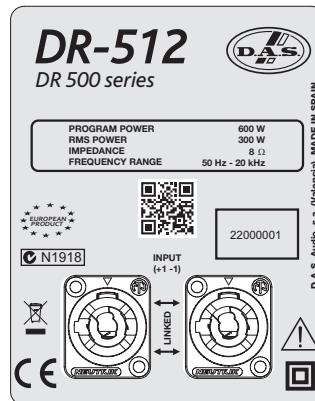
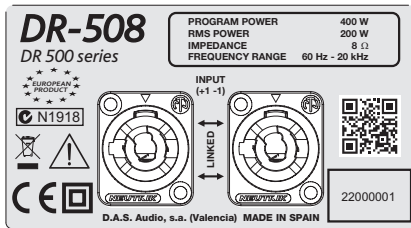

DR-512 (or DR-515)

DR-512 (or DR-515)

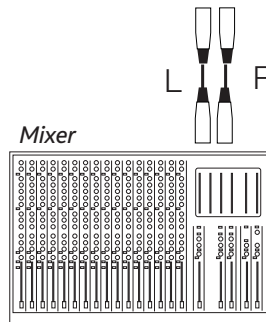
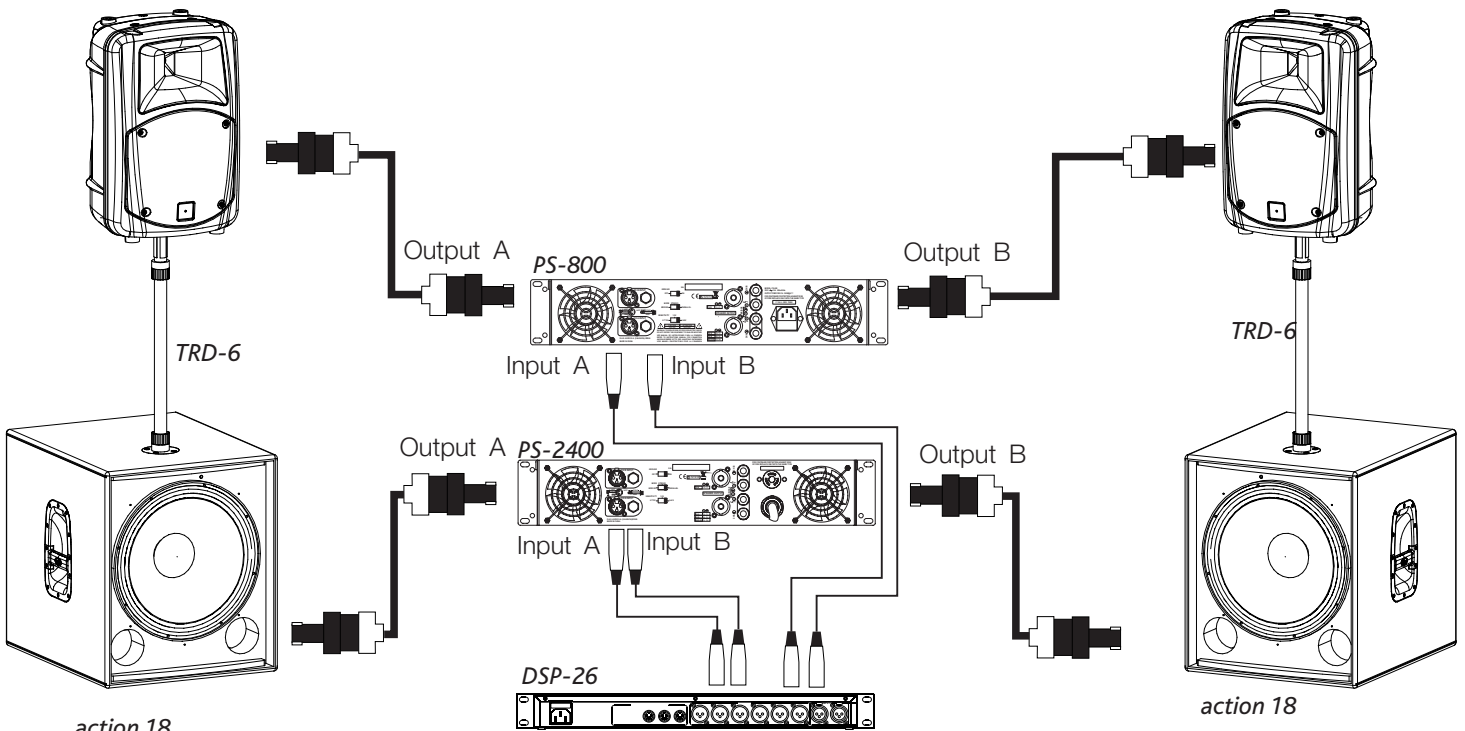

CONFIGURATIONS (cont'd)

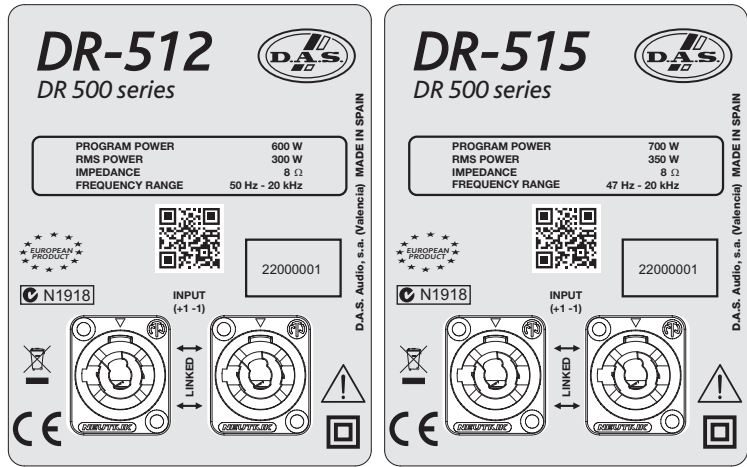

DR-515 (or DR-512)

DR-515 (or DR-512)

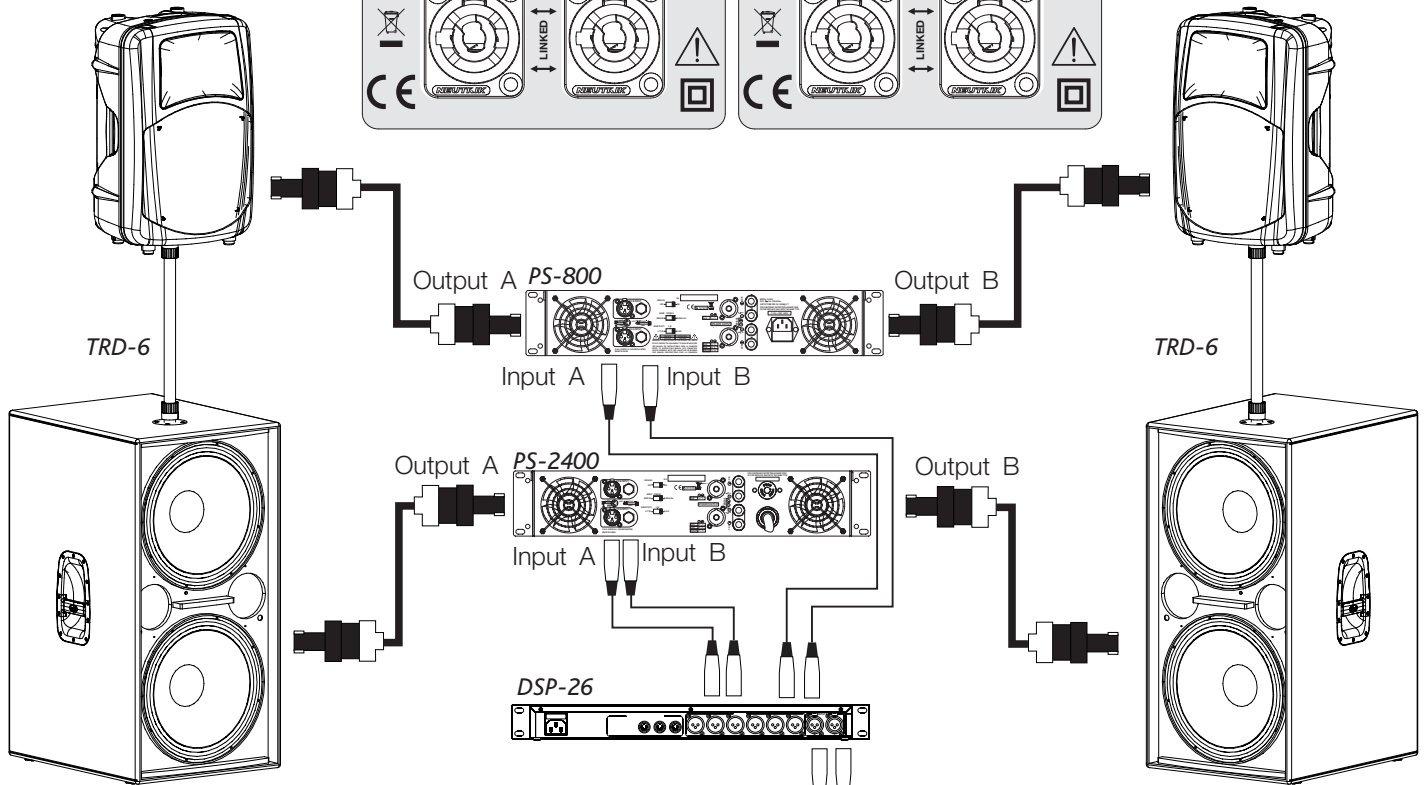

TRD-6

TRD-6

action 218

action 218

L R

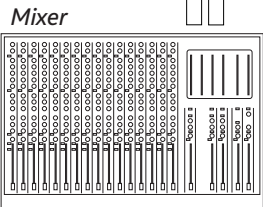

RIGGING SYSTEM

Warnings

This manual contains needed information for flying D.A.S. Audio line array systems, description of the elements and safety precautions. To perform any operations related to flying the system, read the present document first, and act on the warnings and advice given. The goal is to allow the user to become familiar with the mechanical elements required to fly the acoustic system, as well as the safety measures to be taken during set-up and teardown.

Only experienced installers with adequate knowledge of the equipment and local safety regulations should fly speaker boxes. It is the user's responsibility to ensure that the systems to be flown (including flying accessories) comply with state and local regulations.

The working load limits in this manual are the results of tests by independent laboratories. It is the user's responsibility to stay within safe limits. It is the user's responsibility to follow and comply with safety factors, resistance values, periodical supervisions and warnings given in this manual. Product improvement by means of research and development is on going at D.A.S. Specifications are subject to change without notice.

To this date, there is no international standard regarding the flying of acoustic systems. However, it is common practice to apply 5:1 safety factors for enclosures and static elements. For slings and elements exposed to material fatigue due to friction and load variation the following ratios must be met; 5:1 for steel cable slings, 4:1 for steel chain slings and 7:1 polyester slings. Thus, an element with a breaking load limit of 1000 kg may be statically loaded with 200 kg (5:1 safety factor) and dynamically loaded with 142 kg (7:1 safety factor).

When flying a system, the working load must be lower than the resistance of each individual flying point in the enclosure, as well as each box. Hanging hardware should be regularly inspected and suspect units replaced if in doubt. This is important to avoid injury and absolutely no risks should be taken in this respect. It is highly recommended that you implement an inspection and maintenance program on flying elements, including reports to be filled out by the personnel that will carry out the inspections. Local regulations may exist that, in case of accident, may require you to present evidence of inspection reports and corrective actions after defects were found.

Absolutely no risks should be taken with regards to public safety. When flying enclosures from ceiling support structures, extreme care should be taken to assure the load bearing capabilities of the structures so that the installation is absolutely safe. Do not fly enclosures from unsafe structures. Consult a certified professional if needed. All flying accessories that are not supplied by D.A.S. Audio are the user's responsibility. Use at your own risk.

Introduction

Flyable *DR 500 series* models feature 6 internal steel angles, with 2 mounting threads each, so that 12 flying points are available (2 on each side, 3 on the top panel and 3 on the bottom panel and 2 on the rear panel). Eyebolt flying points are factory sealed with M10 screws, which are replaced with eyebolts on the flying points as required. Flying with eyebolts is very economical and safe, and is specially recommended for fixed installations where the boxes are permanently fixed.

The illustration shows the internal metal hardware of an enclosure with eyebolt flying.

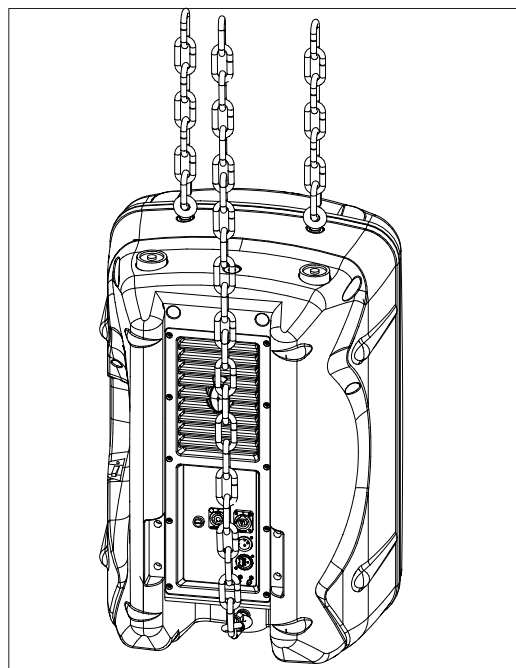

Flying with eyebolts

The Allen-head screws must be removed and replaced by M10 eyebolts on one side of the enclosure. Each rigging point has 200 kg (440 lb) working load limit. Then choose the slings or chains of required load resistance and length, bearing in mind that the length difference between the front and back slings or chains will determine the vertical orientation. Alternatively, the back bottom eyebolt points can be used to provide vertical orientation.

The **ANL-2** set is an optional set of three eyebolts and three carabiners. (Dimensions are in millimetres).

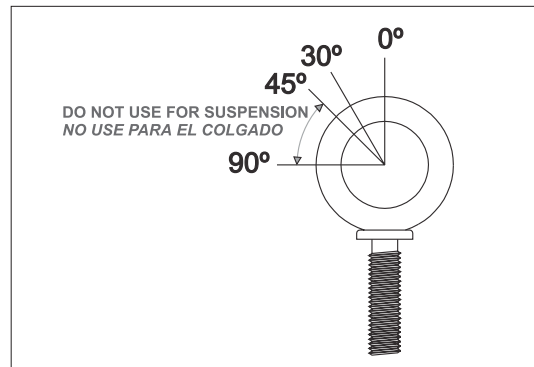

The following illustrations show different views on eyebolt flying for a single box. The length of the back cables or chains determines the vertical angle of the box.

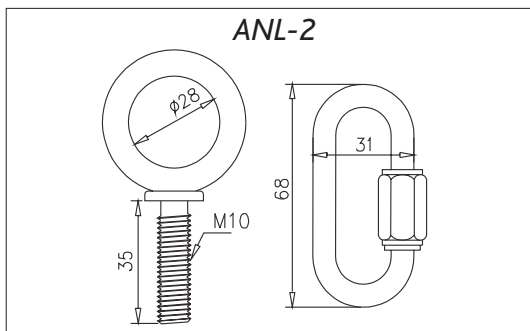

Each **ANL-2** eyebolt has a rated working load of 200 kg. (440 lb). Each **ANL-2** carabiner has a working load of 330 kg (726 lb). If using other hardware, make sure it is rated to handle the required load.

When using eyebolts it is important to bear in mind that the rated working load is only true for a load applied in the plane of the eye, and is significantly reduced for other angles. The drawing illustrates the concept. The table shows the variation of the working load as a function of the load angle. In the case of the **ANL-2** eyebolt, this means that the 200 kg working load becomes 60 kg at 45 degrees. Do not use eyebolt flying if the load angle is higher than 45 degrees.

	0 Degrees	30 Degrees	45 Degrees	More than 45 Degrees
% Working load	100%	65%	30%	25%



AX Mounting

Introduction

AX accessories are specially designed for enclosures *DR-508*, *DR-512*, *DR-515* and different versions.

Mounting instructions

You can consult the mounting instructions of AX for *DR 500 series* on the web: www.dasaudio.com

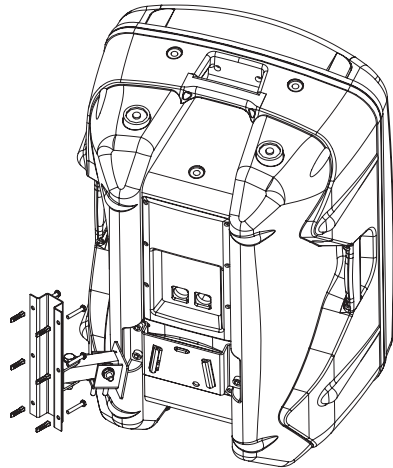

AXM Mounting

Introduction

AXM accessories are specially designed for enclosures *DR 508*, *DR 512* y *DR 515* and different versions.

Mounting instructions

You can consult the mounting instructions of AXM for *DR 500 series* on the web: www.dasaudio.com

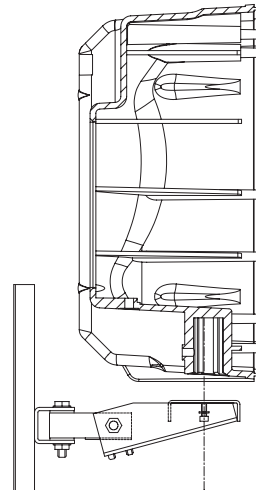

TRD-2 Mounting

Introduction

TRD-2 accessory allows a stand mounting for enclosures *DR-508*, *DR-512*, *DR-515* and different versions.

Mounting instructions

You can consult the mounting instructions of AXM for *DR 500 series* on the web: www.dasaudio.com

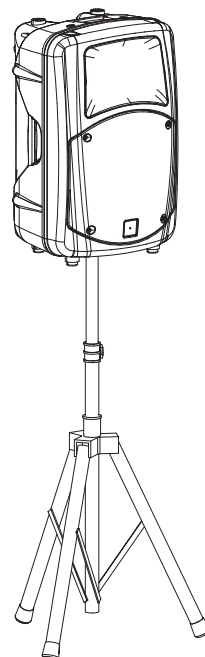

LINE DRAWINGS

ALL DIMENSIONS IN MILLIMETERS

DR 508

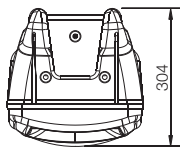

Bottom View

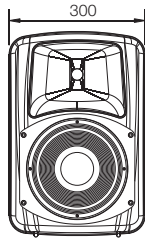

Front View

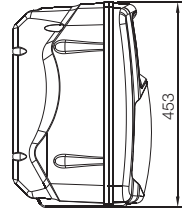

Right View

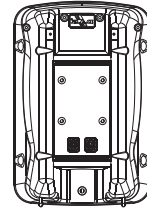

Rear View

DR 512

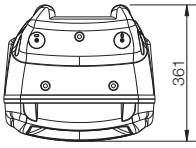

Bottom View

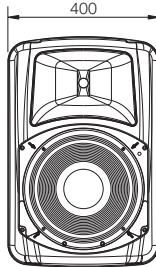

Front View

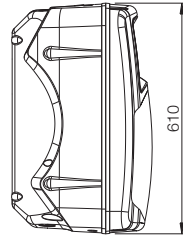

Right View

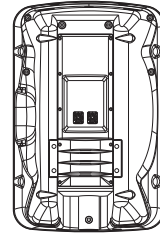

Rear View

DR 515

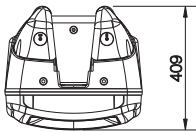

Bottom View

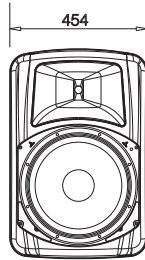

Front View

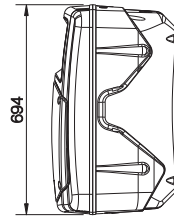

Left View

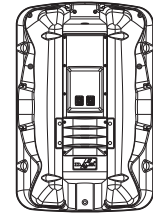

Rear View

SPECIFICATIONS

	DR-508	DR-512	DR-515
Peak Power Handling	800 W	1200 W	1400 W
RMS (Average) Power Handling ¹	200 W	300 W	350 W
Frequency Range (-10 dB)	60 Hz – 20 kHz	50 Hz – 20 kHz	47 Hz – 20 kHz
Nominal Impedance	8 ohms	8 ohms	8 ohms
On-axis Sensitivity 1 W/ 1 m	93 dB SPL	96 dB SPL	96 dB SPL
Maximum Peak SPL at 1 m	122 dB	131 dB	131 dB
HF Horn Coverage Angles (-6dB)	90° x 45°	90° x 45°	90° x 45°
Enclosure Material	Polypropylene	Polypropylene	Polypropylene
Color/Finish	Black	Black	Black
Transducers/Replacement Parts	LF: 8C / GM 8C HF: M-34 / GM M-34	LF: 12Mi / GM 12Mi HF: M-34 / GM M-34	LF: 15Mi / GM 15Mi HF: M-34 / GM M-34
Connectors	2 x NL4 Speakon	2 x NL4 Speakon	2 x NL4 Speakon
Dimensions (H x W x D)	45 x 30 x 30 cm 18 x 12 x 12 in	62 x 40 x 37 cm 24 x 16 x 14.5 in	71 x 46 x 42 cm 28 x 18 x 16.5 in
Weight	9.9 kg (21.8 lb)	16.6 kg (36.5 lb)	18.6 kg (41 lb)
Accessories	ANL-1 AX-108 AX-M FUN-DS-108 TRD-2 TRD-6	ANL-1 AX-115 FUN-DS-112 TRD-2 TRD-6	ANL-1 AX-115 FUN-DS-115 TRD-2 TRD-6

¹ Based on a 2 hour test continuously applying 6 dB crest factor pink noise (IEC shaped).

www.dasaudio.com



D.A.S. AUDIO, S.A.

C/. Islas Baleares, 24
46988 Fuente del Jarro
Valencia, SPAIN
Tel. 96 134 0525
Tel. Intl. +34 96 134 0860
Fax 96 134 0607
Fax Intl. +34 96 134 0607

D.A.S. AUDIO OF AMERICA, INC.

Sunset Palmetto Park
6816 NW 77th Court.
Miami, FL. 33166 - U.S.A.
TOLL FREE: 1-888DAS4USA
Tel. +1 305 436 0521
Fax +1 305 436 0528

D.A.S. AUDIO ASIA PTE. LTD.

25 Kaki Bukit Crescent #01-00/02-00
Kaki Bukit Techpark 1
Singapore 416256
Tel. +65 6742 0151
Fax +65 6742 0157