

SPEAKER SYSTEM

VXS3SB

VXS3SW

SPEAKER ACCESSORY

CMA3SB

CMA3SW

Owner's Manual

EN

Bedienungsanleitung

DE

Mode d'emploi

FR

Manual de instrucciones

ES

Manual do Proprietário

PT

Manuale di istruzioni

IT

Руководство пользователя

RU

使用说明书

ZH

取扱説明書

JA

PRECAUTIONS

PLEASE READ CAREFULLY BEFORE PROCEEDING

Please keep this manual in a safe place for future reference.

WARNING

Always follow the basic precautions listed below to avoid the possibility of serious injury or even death from electrical shock, short-circuiting, damages, fire or other hazards. These precautions include, but are not limited to, the following:

Do not open

- This device contains no user-serviceable parts. Do not open the device or attempt to disassemble the internal parts or modify them in any way. If it should appear to be malfunctioning, discontinue use immediately and have it inspected by qualified Yamaha service personnel.

Water warning

- Do not expose the device to rain, use it near water or in damp or wet conditions. If any liquid such as water seeps into the device, turn off the power of the amplifier immediately. Then have the device inspected by qualified Yamaha service personnel.

Hearing loss

- When turning on the AC power in your audio system, always turn on the power amplifier LAST, to avoid hearing loss and speaker damage. When turning the power off, the

power amplifier should be turned off FIRST for the same reason.

Fire warning

- Do not place any burning items or open flames near the device, since they may cause a fire.

If you notice any abnormality

- If any of the following problems occur, immediately turn off the power of the amplifier.
 - Unusual smells or smoke are emitted.
 - Some object has been dropped into the device.
 - There is a sudden loss of sound during use of the device.
 - Cracks or other visible damage appear on the device.

Then have the device inspected or repaired by qualified Yamaha service personnel.

CAUTION

Always follow the basic precautions listed below to avoid the possibility of physical injury to you or others, or damage to the device or other property. These precautions include, but are not limited to, the following:

Location

- Do not place the device in an unstable position where it might accidentally fall over and cause injuries.
- Do not place the device in a location where it

may come into contact with corrosive gases or salt air. Doing so may result in malfunction.

- Avoid being near the device during a disaster, such as an earthquake. Since the device may fall and cause injury, stay away from the device quickly and move to a safe place.
- Before moving the device, remove all connected cables.
- Be sure to contact a professional installer, if the speaker installation requires construction work, and make sure to observe the following precautions.
 - Choose mounting hardware and an installation location that can support the weight of the device.
 - Avoid locations that are exposed to constant vibration.
 - Use the required tools to install the device.
 - Inspect the device periodically.

Connections

- Use only speaker cables for connecting speakers to the speaker jacks. Use of other types of cables may result in fire.

Handling caution

- Do not place heavy objects on it. Avoid applying excessive force to the buttons, switches or connectors to prevent injuries.
- Do not operate the device if the sound is distorting. Prolonged use in this condition could cause overheating and result in fire.

- Do not input excessively loud signals that may result in clipping in the amplifier or cause the following:
 - Feedback, when using a microphone
 - Continuous and extremely loud sound from a musical instrument, etc.
 - Continuous and excessively loud distorted sound
 - Noise caused by plugging/unplugging the cable while the amplifier is turned on

Even if the output power of the amplifier is lower than the power capacity of this device (program), damage to the device, malfunction or fire may occur.

- When choosing a power amplifier for use with this device, make sure that the output power of the amplifier is lower than the power capacity of this device (see Owner's Manual). If the output power is higher than the power capacity, malfunction or fire may occur.

Yamaha cannot be held responsible for damage caused by improper use or modifications to the device.

PA-8 2/2

NOTICE

To avoid the possibility of malfunction/ damage to the product, or damage to other property, follow the notices below.

Handling and maintenance

When using a high-impedance speaker connection, make sure the audio signal is passed through an 60 Hz or above high-pass filter before being input to the speakers.

Do not install the device to excessive dust or vibration, or extreme cold or heat (such as in direct sunlight, near a heater, or in a car during the day), in order to prevent the possibility of panel disfiguration, unstable operation, or damage to the internal components.

Do not place vinyl, plastic or rubber objects on the device, since this might discolor the device.

When cleaning the device, use a dry and soft cloth. Do not use paint thinners, solvents, cleaning fluids, or chemical-impregnated wiping cloths.

Be sure to observe the amplifier's rated load impedance (see Owner's Manual), particularly when connecting speakers in parallel. Connecting an impedance load outside the amplifier's rated range can damage the amplifier.

Protection Circuit

This speaker system has an internal protection circuit that shuts off the speaker unit when an excessive input signal is applied. If the speaker unit emits no sound, reduce the volume level of the amplifier immediately. The sound will return automatically in several seconds.

Do not place the speaker face down with the grille attached, as deformation of the grille may result.

When placing the speaker face down, always place it on a flat surface.

Avoid touching or allowing objects to come in contact with the speaker diaphragms.

Information

About this manual

The illustrations as shown in this manual are for instructional purposes only.

The company names and product names in this manual are the trademarks or registered trademarks of their respective companies.

Regarding disposal

This product contains recyclable components. When disposing of this product, please contact the appropriate local authorities.

Contents

PRECAUTIONS	2
NOTICE	3
Information	3
Contents	4
Introduction.....	4
Main features.....	4
Included accessories	5
Optional accessories	5
Connections	6
Connect the power amplifier and the VXS3S	6
Set the line voltage/impedance and power	6
Connecting satellites.....	7
Installing on a wall or ceiling	9
Speaker orientation	9
Pre-installation (cable preparation).....	10
Installing in a ceiling (using the CMA3S)	13
Painting.....	16
Painting the grille	16
Painting the speaker enclosure	16
Painting the ceiling mount adaptor	17
Specifications.....	151
Dimensions	152

Introduction

Thank you for purchasing a YAMAHA VXS3SB or VXS3SW (hereafter "VXS3S") speaker system. This product is a subwoofer designed for playing background music in a retail or commercial setting. This manual explains to the installer how to install the product. Additionally, the product can be installed in a ceiling using an optional CMA3SB or CMA3SW (hereafter "CMA3S"). To obtain maximum performance from your YAMAHA speaker system, we recommend that you read this Owner's Manual thoroughly before use. Keep this manual in a safe place for future reference.

Main features

Uses Yamaha's unique SR-Bass™ technology* to provide realistic sound and amazing energy in a small speaker.

- Supports both low-impedance and high-impedance connection in a single speaker.
- Features connection terminals for satellite speakers, allowing you to keep the number of power amplifier channels used to a minimum.

* SR-Bass™ represents the evolution of passive-type diaphragm technology. It is Yamaha's unique bass reproduction technology that efficiently converts the energy inside the speaker cabinet into low-frequency sound.

* The contents of this manual apply to the latest specifications as of the publishing date. To obtain the latest manual, access the Yamaha website then download the manual file.

Included accessories

VXS3S

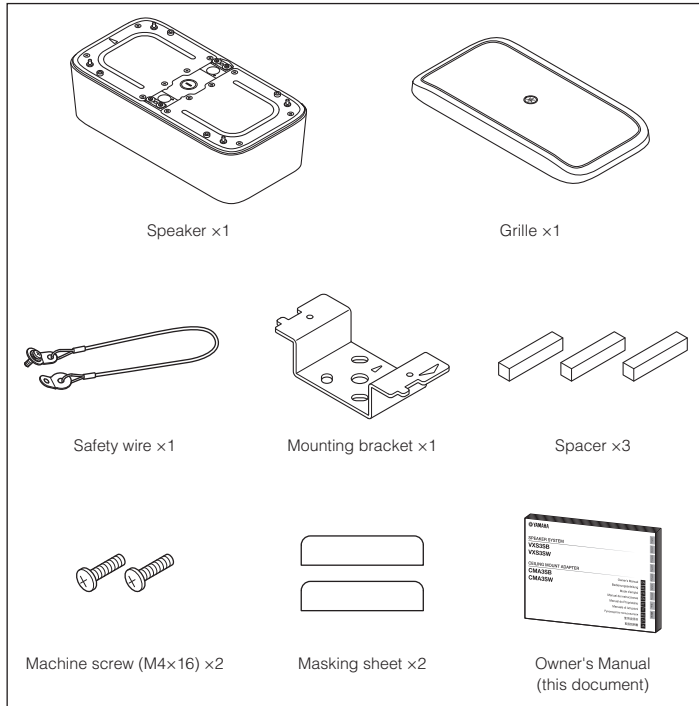

Optional accessories

Ceiling mount adaptor CMA3S

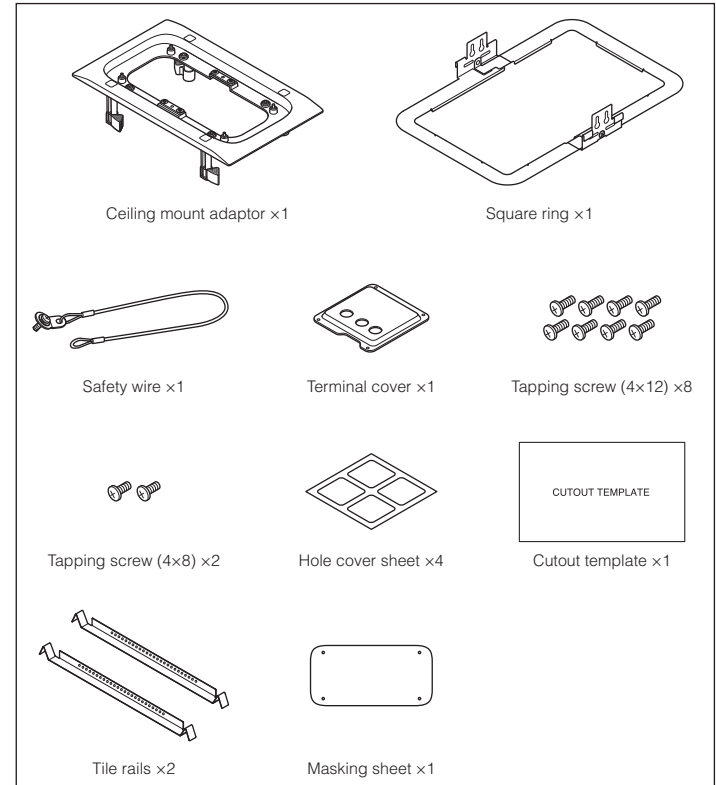

Connections

Connect the power amplifier and the VXS3S

Connect the OUTPUT of the power amplifier to the INPUT of the subwoofer.

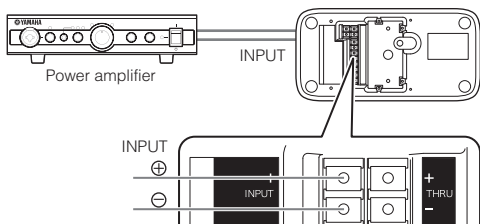

Set the line voltage/impedance and power

Select the line voltage/impedance (100V/70V/8Ω) and input wattage power tap when using a 100V/70V line distributed system.

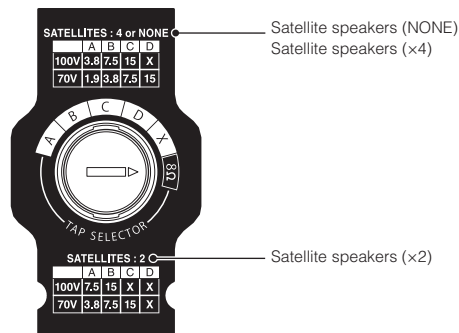

NOTICE

- When connecting speakers with high impedance, check the tap selector switch settings indicated around the switch, and then set the tap according to the number of satellite speaker connections (NONE/x2/x4) and the output (W). Make sure that the input total of each speaker does not exceed the rated output of the power amplifier.
- Do not set the tap selector switch to the "X" position.
- When using a low impedance connection, set the tap selector switch to the "8Ω" position.

If the setting is incorrect, it may cause malfunction of the speaker and amplifier.

- Make sure the amplifier is switched off before operating the tap selector switch.

Connecting satellites

This product features built-in output terminals for connecting satellite speakers. You can connect full-range speakers to the satellite terminals and use them as mid and high-range speakers.

NOTICE

- We recommend the use of 2 or 4 satellite speakers.
- Use caution when mixing 2- and 4-speaker satellite systems, as there may be differences in volume.

■ VXS3S+VXS1ML (×4) low impedance connection

This is a basic system.

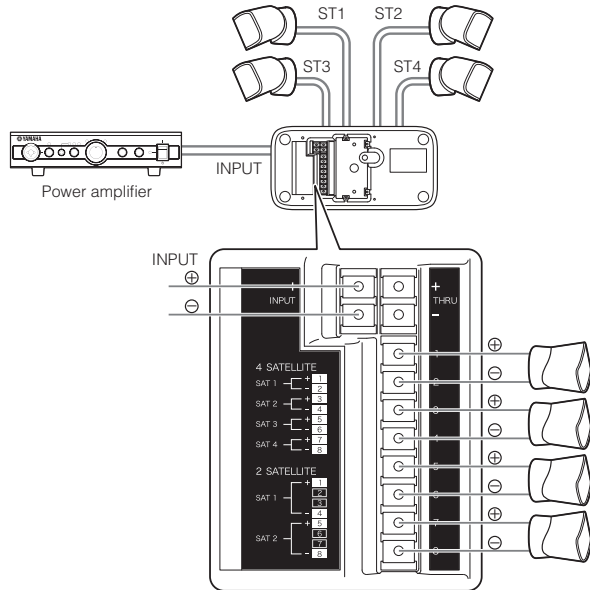

■ VXS3S+VXS1ML (×2) low impedance connection

Connect the speakers as shown below when using only 2 satellite speakers.

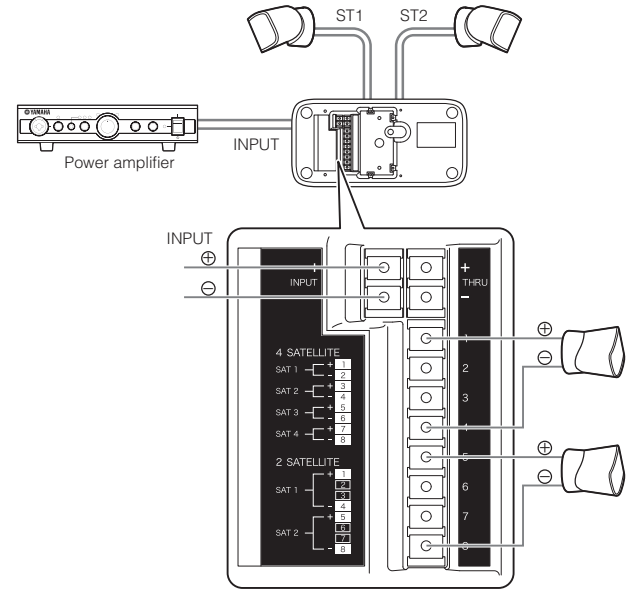

NOTICE

When connecting satellites at low impedance, the combined impedance is 4Ω (when connecting 4 satellites) or 3.5Ω (when connecting 2 satellites). Make sure that the power amplifier is compatible with these impedances. If the power amplifier is not compatible, the power amplifier may malfunction.

■ VXS3S+VXS1ML high impedance connection

This is an example of a system where multiple subwoofers are connected using high impedance connections. Additionally, multiple satellite systems can be connected using just one of the power amplifier's channels.

Set the tap selector switch of the VXS3S according to the number of satellite speaker connections (NONE/x2/x4) and output (W) while referring to the selector switch inscription. For details, refer to page 6.

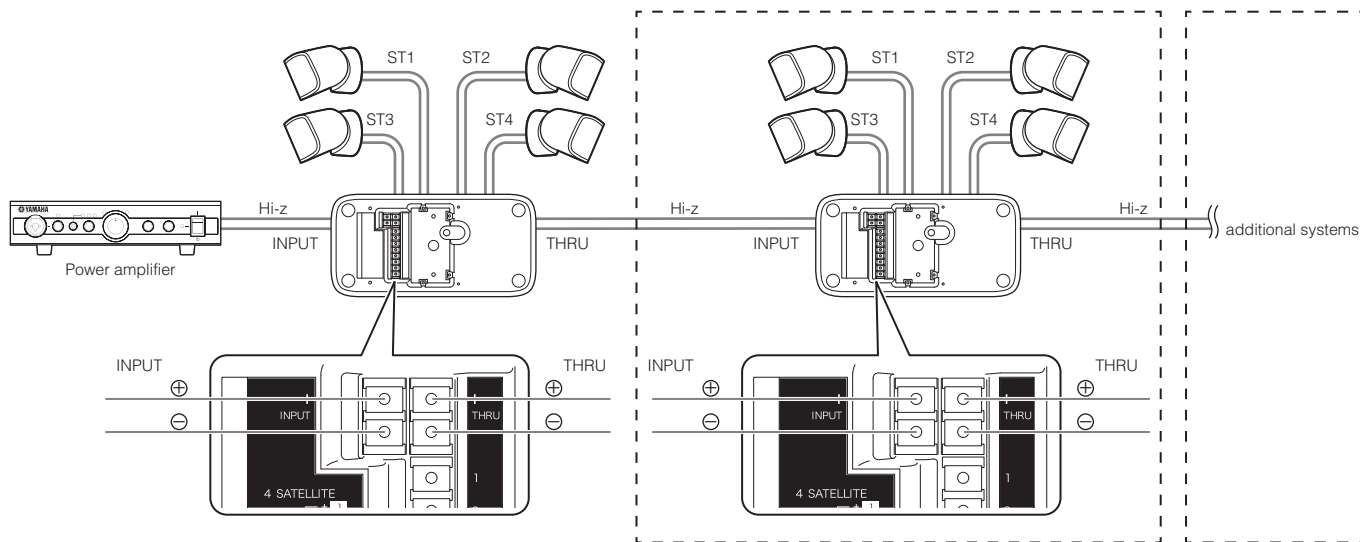

NOTICE

- When connecting speakers with high impedance, be sure that the rated output of the power amplifier exceeds the input total of each speaker.

For details, refer to the explanation of high-impedance connection at the following URL.

Yamaha Pro Audio site, "Better Sound for Commercial Installation"

- When installing speakers, make sure the power amplifier is turned off.
- When connecting at high impedance, the signals inputted into the speaker should be sent through a high-pass filter set to 60Hz or greater.

Installing on a wall or ceiling

You can use the included mounting bracket to install the speaker on a wall or ceiling. Before installation, make sure the installation area can support the weight of the speaker.

NOTICE

When installing speakers, make sure the power amplifier is turned off.

NOTE

If you will paint the speaker, refer to "Painting" on page 16.

Speaker orientation

Install the speaker so that the Δ mark on the mounting bracket is facing the Δ mark on the speaker.

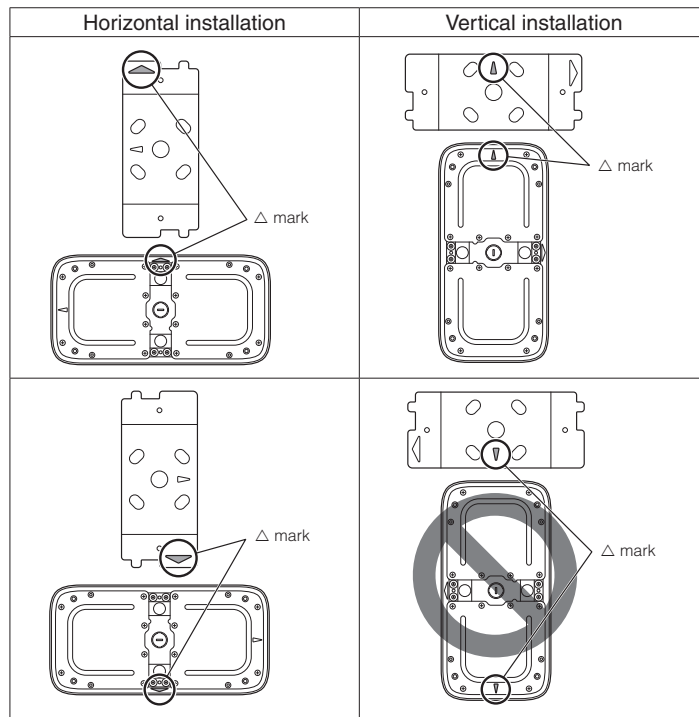
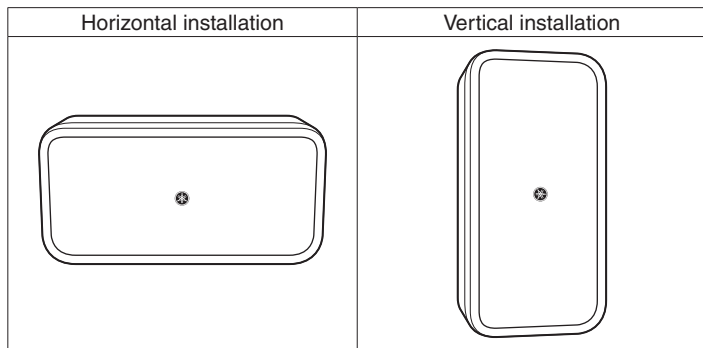

CAUTION

When installing the speaker in a vertical orientation, if the Δ mark on the mounting bracket is pointing down, the speaker cannot be secured to the mounting bracket and it may fall. Do not install the speaker so that the Δ mark points down.

Pre-installation (cable preparation)

Strip the cable insulation as shown in the figure and connect the cables.

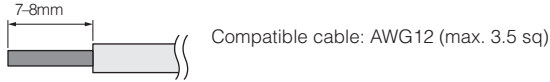

NOTE

- Do not use solder to plate stranded wires, as this may cause the wires to break.
- Run the speaker cables to the installation area before installing the speaker.

1 Attaching the mounting bracket to the wall or ceiling

1-1 Determine the speaker installation location.

1-2 Refer to the figure below and determine where the mounting bracket will be installed and where the cables will be fed.

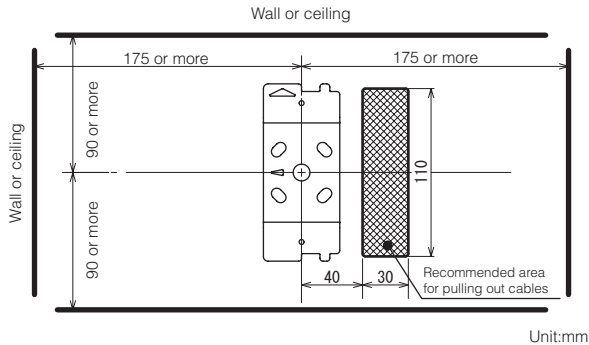

1-3 If you want to add space between the wall and the speaker, attach spacers to the mounting bracket.

When securing at 4 points

When securing at 1 point (center)

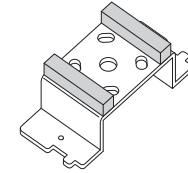
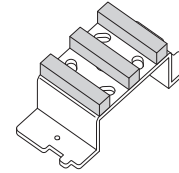

1-4 Attach the mounting bracket to the wall or ceiling.

The 4 slots are for M6 screws, and the center hole's diameter is 11 mm.

1-5 Feed the cables from the wall or ceiling.

2 Attaching the safety wire

2-1 Attach the safety wire to the wall or ceiling.

⚠ CAUTION

- Use the included safety wire.
- Attach safety wire high enough so that there is not too much slack in the wire.
- If the included safety wire is not long enough, consider the weight of the speaker and the installation conditions, and procure an appropriate safety wire.

- 2-2** Attach the safety wire to the speaker.
Attach the safety wire so that its clasp fits inside the groove on the speaker.

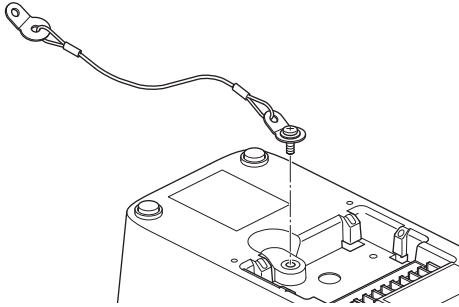

3 Connecting the cables

- 3-1** Use a Phillips screwdriver to loosen the screws on the barrier strip, insert the cables, and then tighten the screws. For information about connecting the cables, refer to "Connections" on page 6. Make sure the cables are secure and cannot be pulled out.

4 Secure the speaker to the mounting bracket

- 4-1** Remove the grille.
4-2 Attach the speaker so that the Δ mark on the mounting bracket is facing the Δ mark on the speaker.

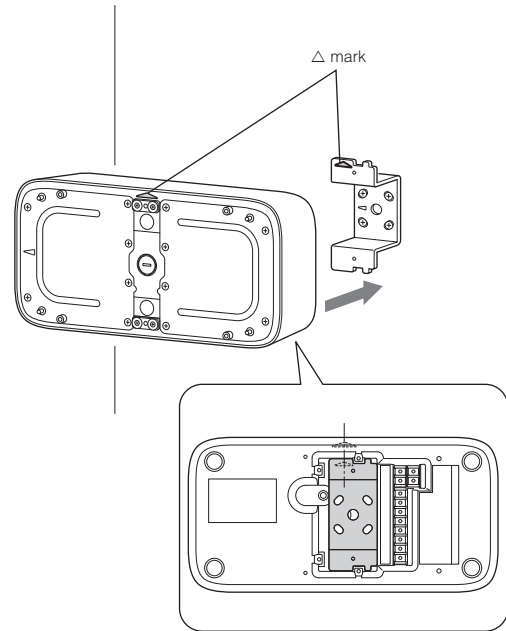

- 4-3** Slide the speaker about 10mm in the direction shown to temporarily secure the speaker.

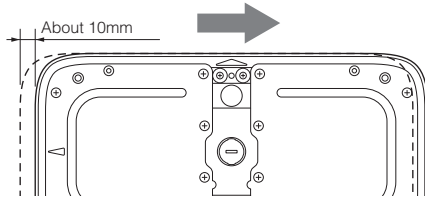

- 4-4** Use the supplied two screws to secure the speaker.

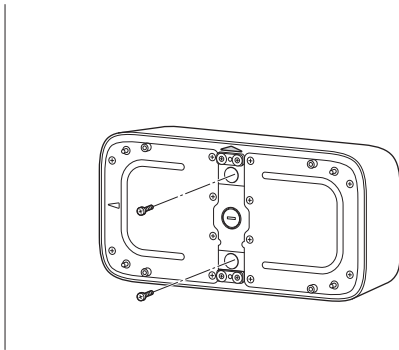

⚠ CAUTION

Make sure you tighten the screws.

NOTICE

When installing the speaker, make sure you do not touch the flaps or subject the speaker to strong shocks. If the flaps become indented, the sound may become distorted.

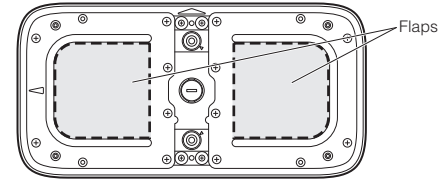

5 Setting the line voltage/impedance and power

- 5-1** Set the line voltage/impedance (100V/70V/8Ω) and input wattage when using a 100V/70V line distributed system. For details, refer to page 6.

6 Attach the grille

- 6-1** Align the grille to the front of the cabinet and attach the grille.

⚠ CAUTION

If the grille is not attached properly, it may fall off after the speaker is installed.

Installing in a ceiling (using the CMA3S)

You can use the optional VXS3S ceiling mount adaptor to install the speaker in a ceiling.

1 Cut a hole in the ceiling

- 1-1** Use the included cutout template (350mm×210mm) to mark the outline of the hole on the ceiling.

NOTE

Make sure to use the included cutout template; if the hole size is not correct, you will not be able to install the speaker.

- 1-2** Cut along the outline and cut the hole.
When cutting the hole, be careful to prevent debris or dust from entering your eyes.

2 Attach the square ring and rails to the inside surface of the ceiling.

- 2-1** Insert the two tile rails through the cut hole and place them on the ceiling surface within your reach. Be sure that each tile rails are oriented as shown in the illustration.
- 2-2** Insert the square-ring through the cut hole.

- 2-3** Secure the square-ring and tile rails with supplied two screws through either slot of both square-ring brackets.

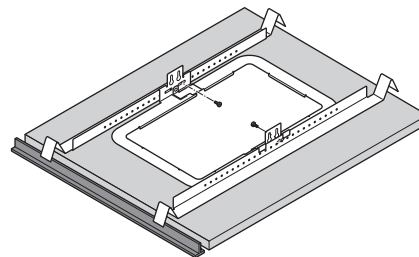

3 Attach the ceiling mount adaptor to the speaker.

3-1 Remove the grille.

3-2 Insert the speaker into the ceiling mount adaptor, and secure the speaker using the supplied four screws.

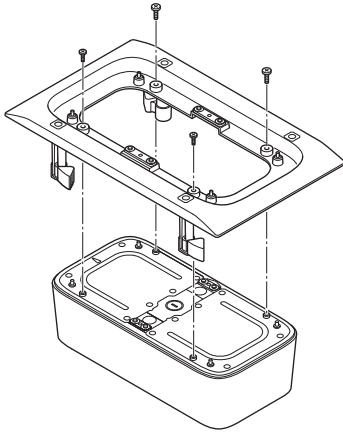

4 Attach the safety wire

4-1 Refer to Step 2 on page 10.

Use the safety wire included with the CMA3S.

5 Connecting the cables

5-1 Feed the cables through the hole in the ceiling.

5-2 Run the cables through the terminal cover.

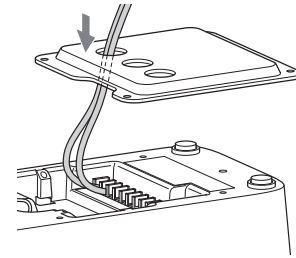

5-3 Use a Phillips screwdriver to loosen the screws on the barrier strip, insert the cables, and then tighten the screws. For information about connecting the cables, refer to "Connections" (page 6). Make sure the cables are secure and cannot be pulled out.

5-4 Tighten the screws and attach the terminal cover.

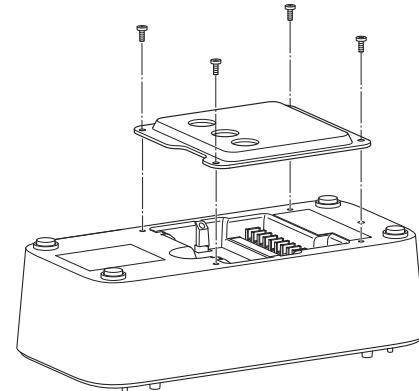

6 Secure the speaker to the ceiling

6-1 Push the speaker into the ceiling, taking care not to pinch the cables.

NOTICE

When installing the speaker, make sure you do not touch the flaps or subject the speaker to strong shocks. If the flaps become indented, the sound may become distorted.

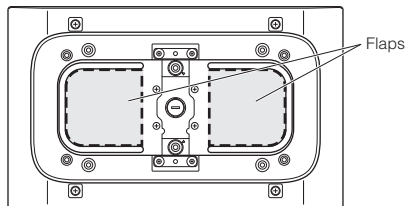

6-2 While lifting the speaker up slightly, use a Phillips screwdriver to turn the screws clockwise and tighten the attachments screws. The clamp opens when you begin turning the screw. As you continue to turn the screw, the clamp slides down and pulls the speaker into the ceiling.

NOTE

If the clamp is difficult to open, turn the screw counter-clockwise one-half revolution; this will make it easier to open.

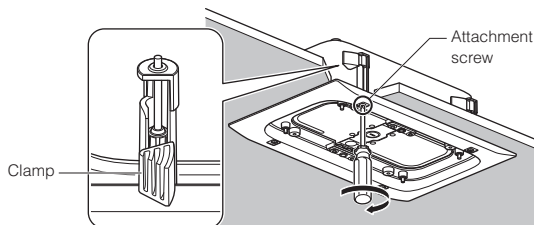

⚠ CAUTION

- To prevent stripping the screws, do not overtighten the screws.
- Do not turn any screws other than the attachment screws. This may cause the speaker to fall or malfunction.

7 Setting the line voltage/impedance and power

7-1 Refer to page 6.

8 Attach the hole cover sheets

8-1 Attach the included hole cover sheets to the screw holes.

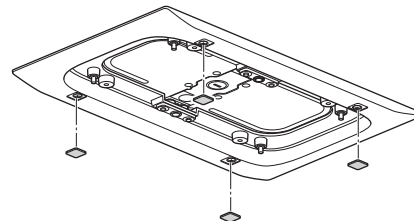

9 Attach the grille

9-1 Align the grille to the front of the cabinet and attach the grille.

⚠ CAUTION

If the grille is not attached properly, it may fall off after the speaker is installed.

Painting

When painting the VXS3S, we recommend using acrylic lacquer paint. Refer to the paint's instructions for details on how to apply the paint.

CAUTION

Work in an area that has adequate ventilation.

NOTICE

- Painting procedures often require the use of volatile solvents that can cause fire. Follow all necessary safety precautions to avoid any risk of a fire or accident.
- Yamaha cannot be held responsible for any damage to the speaker as a result of painting.

Painting the grille

- 1 Remove the grille from the speaker, taking care not to scratch it.
- 2 Remove the emblem on the front of the grille.
The emblem is attached by adhesive tape.
- 3 Tuck the included masking sheet under the crosspiece on the back of the grille and insert the masking sheet.

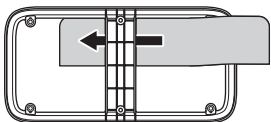

NOTE

Make sure the areas shown below are covered.

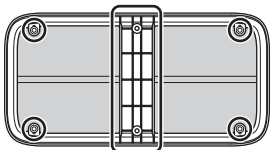

- 4 Apply the paint to the grille.

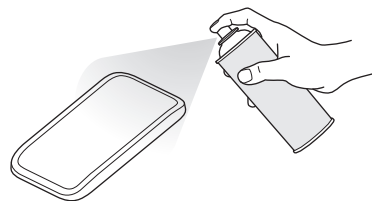

NOTE

Make sure the holes in the grille do not become clogged with paint. If the holes become clogged with paint, sound quality may be affected.

- 5 When the paint is completely dry, remove the masking sheet and attach the emblem to the grille.
Make sure the emblem is attached in the correct position.
- 6 Attach the grille to the speaker.

Painting the speaker enclosure

- 1 Remove any dust or dirt with a lint-free cloth.
Do not sand the enclosure.
- 2 Use spray paint to paint the enclosure.
Cover the baffle and connectors using masking materials to avoid paint contact.

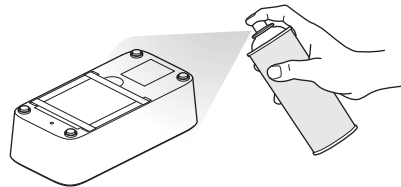

- 3 Allow the paint to dry completely.

Painting the ceiling mount adaptor

- 1 Wipe off any dirt from the ceiling mount adaptor before painting it. Do not file it down.
- 2 Align the included masking sheet with the posts of the ceiling mount adaptor and insert the masking sheet.

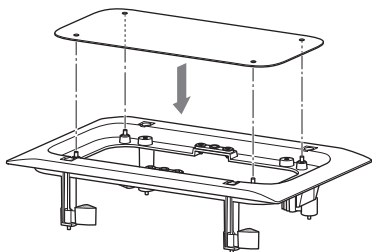

- 3 Use masking tape to cover the posts and the screw heads (8 locations total).

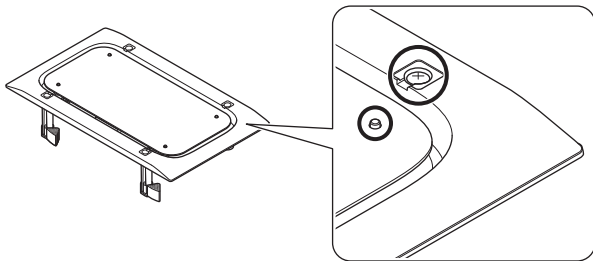

NOTE

Use masking tape as necessary to mask other areas.

- 4 Spray the paint onto the ceiling mount adaptor and the hole cover sheets.

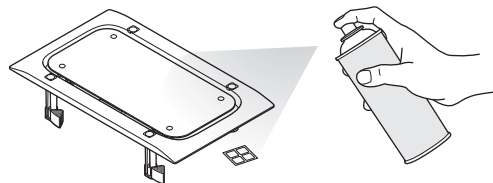

- 5 When the paint is completely dry, remove the masking sheet.

Specifications

Model		VXS3SB	VXS3SW			
Type		SR-Bass™ type Subwoofer				
Component		3.5" (9cm) Cone				
Nominal impedance		Lo-Z: 8Ω Hi-Z: 4 Satellites or None				
			15W	7.5W	3.8W	1.9W
		100V	670Ω	1.3kΩ	2.7kΩ	-
		70V	330Ω	670Ω	1.3kΩ	2.7kΩ
		2 Satellites				
		15W	7.5W	3.8W		
		100V	1.3kΩ	2.7kΩ	-	
		70V	670Ω	1.3kΩ	2.7kΩ	
Satellite impedance		8Ω (Load per satellite output recommended)				
Power rating	NOISE	20W				
	PGM	40W				
	MAX	80W				
Sensitivity (1W, 1m)*1		79dB SPL				
Maximum SPL (Calculated, 1m)*2		98dB SPL				
Frequency range (-10dB)		65Hz - 180Hz				
Connector		TERMINAL BLOCKS(4pin) Input: +/-, Loop-thru: +/- TERMINAL BLOCKS(8pin) Satellite output: +/- (ST1~ST4) Max. wire size AWG 12(3.5sq)				
Transformer	70V line	15W, 7.5W, 3.8W, 1.9W				
Taps	100V line	15W, 7.5W, 3.8W				
Overload protection		Full-range power limiting to protecting network and transducers				

Model		VXS3SB	VXS3SW
Magnetically shielded		No	
Enclosure	Cabinet Material	ABS (V-0) 5mm Black	ABS (V-0) 5mm White
	Baffle Material	ABS (V-0) 3.5mm Black	
Grille	Material	Powder coated perforated steel (t=0.6mm) Grille Frame: ABS (V-0)	
	Finish	Black painting (approximate value: Munsell N3)	White painting (approximate value: Munsell N9)
	Aperture ratio	55%	55%
Dimension (Speaker only)		W322 × H162 × D118mm (12 5/8" × 6 3/8" × 4 5/8")	
Net Weight (Speaker only)		2.7 kg (6.0 lbs)	
Packaging		Packaged in 1pc	

*1 : Full-space (4π)

*2 : Calculated based on power rating and sensitivity, exclusive of power compression.

Model	CMA3SB	CMA3SW
Enclosure	ABS (V-0) 3.0mm Black	ABS (V-0) 3.0mm White
Dimensions (Adapter only)	W386 × D233 × H90mm (15 1/4" × 9 1/4" × 3 1/2")	
Net Weight	0.44 kg (0.97 lbs)	
Cutout size	350mm × 210mm (13 3/4" × 8 1/4")	

Dimensions

VXS3SB/VXS3SW

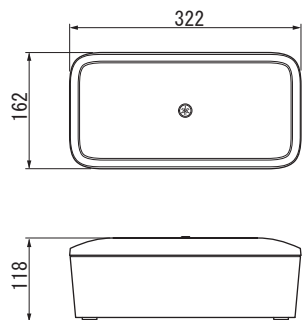

■ WALL BRACKET

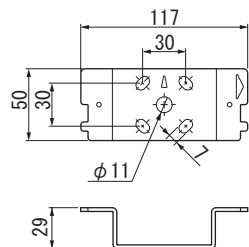

CMA3SB/CMA3SW (OPTION)

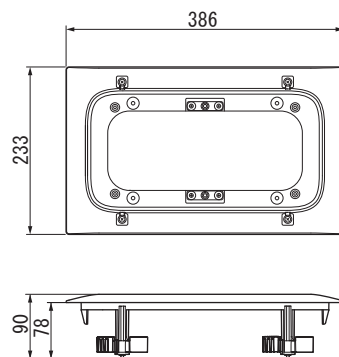

■ SQUARE RING

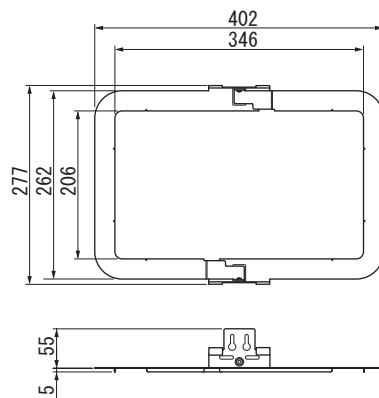

■ ANCHOR BRACKET AND SQUARE RING

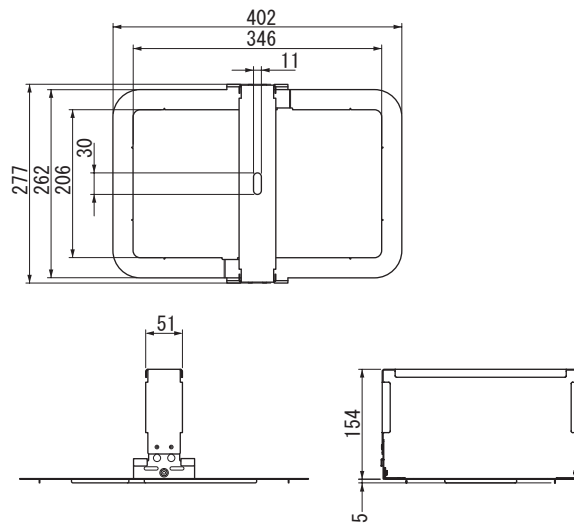

■ TILE RAIL

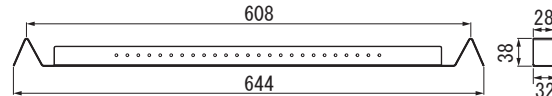

Unit: mm

产品中有害物质的名称及含量

部件名称	有害物质					
	铅 (Pb)	汞 (Hg)	镉 (Cd)	六价铬 (Cr(VI))	多溴联苯 (PBB)	多溴二苯醚 (PBDE)
外壳、框架	×	○	○	○	○	○
印刷线路板	×	○	○	○	○	○
电缆类	×	○	○	○	○	○
扩音装置	×	○	○	○	○	○

本表格依据 SJ/T 11364 的规定编制。
 ○：表示该有害物质在该部件所有均质材料中的含量均在 GB/T 26572 规定的限量要求以下。
 ×：表示该有害物质至少在该部件的某一均质材料中的含量超出 GB/T 26572 规定的限量要求。



此标识适用于在中华人民共和国销售的电器电子产品。标识中间的数字为环保使用期限的年数。

保护环境

如果需要废弃设备时，请与本地相关机构联系，获取正确的废弃方法。请勿将设备随意丢弃或作为生活垃圾处理。



仅适用于非热带气候条件下安全使用。

“*අනුමත වන අවස්ථාවේ පමණක් භාවිතයට යොදා ගත හැකි වන බවට අවදානමක් ඇත.*”

“*සඳහා වන භාවිතයට නොමැතිව සිටින විට භාවිතයට නොමැතිව තබා ගත යුතු බවට අවදානමක් ඇත.*”

دې ھېرى ئىسسىق ھەۋەردە بىخەتەر ئىشلەتكىلى بولىدۇ

Dan hab yungh youq gij diehneiq diuzgen mboug dwg diegndat haenx ancienz sawjyungh.



仅适用于海拔 2000m 以下地区安全使用。

“*2000m ට අඩු උසකට පමණක් භාවිතයට යොදා ගත හැකි වන බවට අවදානමක් ඇත.*”

“*2000m ට ඊට වැඩි උසකට භාවිතයට නොමැතිව තබා ගත යුතු බවට අවදානමක් ඇත.*”

دې ھېرى 2000 مېتىر يۇرتىدىن تۆۋەن رايونلاردا بىخەتەر ئىشلەتكىلى بولىدۇ

Dan hab yungh youq gij digih haijbaz 2 000m doxroengz haenx ancienz sawjyungh.

关于产品上所示的图标，请按照相应图标的上述说明进行操作。

“*අනුමත වන අවස්ථාවේ පමණක් භාවිතයට යොදා ගත හැකි වන බවට අවදානමක් ඇත.*”

සඳහා වන භාවිතයට නොමැතිව සිටින විට භාවිතයට නොමැතිව තබා ගත යුතු බවට අවදානමක් ඇත.

دې ھېرى ئىسسىق ھەۋەردە بىخەتەر ئىشلەتكىلى بولىدۇ

Doiq gjidz veh youq gwnc canjbinj haenx, cingj mwngz ciuq gijssaw sij youq gwngzdoz doiqndei le menh baeczamq baeczamq ma guh.

Information for users on collection and disposal of old equipment:



This symbol on the products, packaging, and/or accompanying documents means that used electrical and electronic products should not be mixed with general household waste. For proper treatment, recovery and recycling of old products, please take them to applicable collection points, in accordance with your national legislation.

By disposing of these products correctly, you will help to save valuable resources and prevent any potential negative effects on human health and the environment which could otherwise arise from inappropriate waste handling.

For more information about collection and recycling of old products, please contact your local municipality, your waste disposal service or the point of sale where you purchased the items.

For business users in the European Union:

If you wish to discard electrical and electronic equipment, please contact your dealer or supplier for further information.

Information on Disposal in other Countries outside the European Union:

This symbol is only valid in the European Union. If you wish to discard these items, please contact your local authorities or dealer and ask for the correct method of disposal.

(weee_eu_en_02)

Verbraucherinformation zur Sammlung und Entsorgung alter Elektrogeräte



Befindet sich dieses Symbol auf den Produkten, der Verpackung und/oder beiliegenden Unterlagen, so sollten benutzte elektrische Geräte nicht mit dem normalen Haushaltsabfall entsorgt werden.

In Übereinstimmung mit Ihren nationalen Bestimmungen bringen Sie alte Geräte bitte zur fachgerechten Entsorgung, Wiederaufbereitung und Wiederverwendung zu den entsprechenden Sammelstellen.

Durch die fachgerechte Entsorgung der Elektrogeräte helfen Sie, wertvolle Ressourcen zu schützen, und verhindern mögliche negative Auswirkungen auf die menschliche Gesundheit und die Umwelt, die andernfalls durch unsachgerechte Müllentsorgung auftreten könnten.

Für weitere Informationen zum Sammeln und Wiederaufbereiten alter Elektrogeräte kontaktieren Sie bitte Ihre örtliche Stadt- oder Gemeindeverwaltung, Ihren Abfallentsorgungsdienst oder die Verkaufsstelle der Artikel.

Information für geschäftliche Anwender in der Europäischen Union:

Wenn Sie Elektrogeräte ausrangieren möchten, kontaktieren Sie bitte Ihren Händler oder Zulieferer für weitere Informationen.

Entsorgungsinformation für Länder außerhalb der Europäischen Union:

Dieses Symbol gilt nur innerhalb der Europäischen Union. Wenn Sie solche Artikel ausrangieren möchten, kontaktieren Sie bitte Ihre örtlichen Behörden oder Ihren Händler und fragen Sie nach der sachgerechten Entsorgungsmethode.

(weee_eu_de_02)

Informations concernant la collecte et le traitement des déchets d'équipements électriques et électroniques



Le symbole sur les produits, l'emballage et/ou les documents joints signifie que les produits électriques ou électroniques usagés ne doivent pas être mélangés avec les déchets domestiques habituels.

Pour un traitement, une récupération et un recyclage appropriés des déchets d'équipements électriques et électroniques, veuillez les déposer aux points de collecte prévus à cet effet, conformément à la réglementation nationale.

En vous débarrassant correctement des déchets d'équipements électriques et électroniques, vous contribuerez à la sauvegarde de précieuses ressources et à la prévention de potentiels effets négatifs sur la santé humaine qui pourraient advenir lors d'un traitement inapproprié des déchets.

Pour plus d'informations à propos de la collecte et du recyclage des déchets d'équipements électriques et électroniques, veuillez contacter votre municipalité, votre service de traitement des déchets ou le point de vente où vous avez acheté les produits.

Pour les professionnels dans l'Union européenne :

Si vous souhaitez vous débarrasser des déchets d'équipements électriques et électroniques, veuillez contacter votre vendeur ou fournisseur pour plus d'informations.

Informations sur la mise au rebut dans d'autres pays en dehors de l'Union européenne :

Ce symbole est seulement valable dans l'Union européenne. Si vous souhaitez vous débarrasser de déchets d'équipements électriques et électroniques, veuillez contacter les autorités locales ou votre fournisseur et demander la méthode de traitement appropriée.

(weee_eu_fr_02)

Información para usuarios sobre la recogida y eliminación de los equipos antiguos



Este símbolo en los productos, embalajes y documentos anexos significa que los productos eléctricos y electrónicos no deben mezclarse con los desperdicios domésticos normales.

Para el tratamiento, recuperación y reciclaje apropiados de los productos antiguos, llévelos a puntos de reciclaje correspondientes, de acuerdo con la legislación nacional.

Al deshacerse de estos productos de forma correcta, ayudará a ahorrar recursos valiosos y a impedir los posibles efectos desfavorables en la salud humana y en el entorno que de otro modo se producirían si se tratan los desperdicios de modo inapropiado.

Para obtener más información acerca de la recogida y el reciclaje de los productos antiguos, póngase en contacto con las autoridades locales, con el servicio de eliminación de basuras o con el punto de venta donde adquirió los artículos.

Para los usuarios empresariales de la Unión Europea:

Si desea deshechar equipos eléctricos y electrónicos, póngase en contacto con su vendedor o proveedor para obtener más información.

Información sobre la eliminación en otros países fuera de la Unión Europea:

Este símbolo solo es válido en la Unión Europea. Si desea deshechar estos artículos, póngase en contacto con las autoridades locales o con el vendedor y pregúnteles el método correcto.

(weee_eu_es_02)

Informazioni per gli utenti sulla raccolta e lo smaltimento di vecchia attrezzatura



Questi simboli sui prodotti, sull'imballaggio e/o sui documenti che li accompagnano, indicano che i prodotti elettrici ed elettronici non devono essere mischiati con i rifiuti generici.

Per il trattamento, il recupero e il riciclaggio appropriato di vecchi prodotti, si prega di portarli ai punti di raccolta designati, in accordo con la legislazione locale.

Smaltendo correttamente questi prodotti si potranno recuperare risorse preziose, oltre a prevenire potenziali effetti negativi sulla salute e l'ambiente che potrebbero sorgere a causa del trattamento improprio dei rifiuti.

Per ulteriori informazioni sulla raccolta e il riciclaggio di vecchi prodotti, si prega di contattare l'amministrazione comunale locale, il servizio di smaltimento dei rifiuti o il punto vendita dove sono stati acquistati gli articoli.

Per utenti imprenditori dell'Unione europea:

Se si desidera scartare attrezzatura elettrica ed elettronica, si prega di contattare il proprio rivenditore o il proprio fornitore per ulteriori informazioni.

Informazioni sullo smaltimento negli altri Paesi al di fuori dell'Unione europea:

Questi simboli sono validi solamente nell'Unione Europea; se si desidera scartare questi articoli, si prega di contattare le autorità locali o il rivenditore e richiedere informazioni sulla corretta modalità di smaltimento.

(weee_eu_it_02)

Informações para os utilizadores relativos à recolha e eliminação de equipamentos usados



Este símbolo, presente em produtos, embalagens e/ou incluído na documentação associada, indica que os produtos elétricos e eletrônicos usados não devem ser eliminados juntamente com os resíduos domésticos em geral.

O procedimento correto consiste no tratamento, recuperação e reciclagem de produtos usados, pelo que deve proceder à respetiva entrega nos pontos de recolha adequados, em conformidade com a legislação nacional em vigor.

A eliminação destes produtos de forma adequada permite poupar recursos valiosos e evitar potenciais efeitos prejudiciais para a saúde pública e para o ambiente, associados ao processamento incorreto dos resíduos.

Para mais informações relativas à recolha e reciclagem de produtos usados, contacte as autoridades locais, o serviço de eliminação de resíduos ou o ponto de venda onde foram adquiridos os itens relevantes.

Informações para utilizadores empresariais na União Europeia:

Para proceder à eliminação de equipamento elétrico e eletrónico, contacte o seu revendedor ou fornecedor para obter informações adicionais.

Informações relativas à eliminação em países não pertencentes à União Europeia:

Este símbolo é válido exclusivamente na União Europeia. Caso pretenda eliminar este tipo de itens, contacte as autoridades locais ou o seu revendedor e informe-se acerca do procedimento correto para proceder à respetiva eliminação.

(weee_eu_pt_02a)

Important Notice: Guarantee Information for customers in European Economic Area (EEA) and Switzerland

<p>Important Notice: Guarantee Information for customers in EEA* and Switzerland</p> <p>For detailed guarantee information about this Yamaha product, and Pan-EEA* and Switzerland warranty service, please either visit the website address below (Printable file is available at our website) or contact the Yamaha representative office for your country. * EEA: European Economic Area</p>	English
<p>Wichtiger Hinweis: Garantie-Information für Kunden in der EWR* und der Schweiz</p> <p>Für nähere Garantie-Information über dieses Produkt von Yamaha, sowie über den Pan-EWR*- und Schweizer Garantieservice, besuchen Sie bitte entweder die folgende angegebene Internetadresse (eine druckfähige Version befindet sich auch auf unserer Webseite), oder wenden Sie sich an den für Ihr Land zuständigen Yamaha-Vertrieb. *EWR: Europäischer Wirtschaftsraum</p>	Deutsch
<p>Remarque importante: informations de garantie pour les clients de l'EEE et la Suisse</p> <p>Pour des informations plus détaillées sur la garantie de ce produit Yamaha et sur le service de garantie applicable dans l'ensemble de l'EEE ainsi qu'en Suisse, consultez notre site Web à l'adresse ci-dessous (le fichier imprimable est disponible sur notre site Web) ou contactez directement Yamaha dans votre pays de résidence. * EEE : Espace Economique Européen</p>	Français
<p>Belangrijke mededeling: Garantie-informatie voor klanten in de EER* en Zwitserland</p> <p>Voor gedetailleerde garantie-informatie over dit Yamaha-product en de garantieservice in heel de EER* en Zwitserland, gaat u naar de onderstaande website (u vind een afdrukbaar bestand op onze website) of neemt u contact op met de vertegenwoordiging van Yamaha in uw land. * EER: Europese Economische Ruimte</p>	Nederlands
<p>Aviso importante: información sobre la garantía para los clientes del EEE* y Suiza</p> <p>Para una información detallada sobre este producto Yamaha y sobre el soporte de garantía en la zona EEE* y Suiza, visite la dirección web que se incluye más abajo (la versión del archivo para imprimir está disponible en nuestro sitio web) o póngase en contacto con el representante de Yamaha en su país. * EEE: Espacio Económico Europeo</p>	Español
<p>Avviso importante: informazioni sulla garanzia per i clienti residenti nell'EEA* e in Svizzera</p> <p>Per informazioni dettagliate sulla garanzia relativa a questo prodotto Yamaha e l'assistenza in garanzia nei paesi EEA* e in Svizzera, potete consultare il sito Web all'indirizzo riportato di seguito (è disponibile il file in formato stampabile) oppure contattare l'ufficio di rappresentanza locale della Yamaha. * EEA: Area Economica Europea</p>	Italiano
<p>Aviso importante: informações sobre as garantias para clientes da AEE* e da Suíça</p> <p>Para obter uma informação pormenorizada sobre este produto da Yamaha e sobre o serviço de garantia na AEE* e na Suíça, visite o site a seguir (o arquivo para impressão está disponível no nosso site) ou entre em contato com o escritório de representação da Yamaha no seu país. * AEE: Área Económica Europeia</p>	Português
<p>Σημαντική σημείωση: Πληροφορίες εγγύησης για τους πελάτες στον EOX* και Ελβετία</p> <p>Για λεπτομερείς πληροφορίες εγγύησης σχετικά με το παρόν προϊόν της Yamaha και την κάλυψη εγγύησης σε όλες τις χώρες του EOX και την Ελβετία, επισκεφτείτε την παρακάτω ιστοσελίδα (Εκτυπώσιμη μορφή είναι διαθέσιμη στην ιστοσελίδα μας) ή απευθυνθείτε στην αντιπροσωπεία της Yamaha στη χώρα σας. * EOX: Ευρωπαϊκός Οικονομικός Χώρος</p>	Ελληνικά
<p>Viktigt: Garantierinformation för kunder i EES-området* och Schweiz</p> <p>För detaljerad information om denna Yamahaproduct samt garantierinformation i hela EES-området* och Schweiz kan du antingen besöka nedanstående webbadress (en utskriftsvänlig fil finns på webbplatsen) eller kontakta Yamahas officiella representant i ditt land. * EES: Europeiska Ekonomiska Samarbetsområdet</p>	Svenska
<p>Viktig merknad: Garantierinformasjon for kunder i EØS* og Sveits</p> <p>Detaljert garantierinformasjon om dette Yamaha-produktet og garantierinformasjon for hele EØS-området* og Sveits kan fås enten ved å besøke nettstedssiden nedenfor (utskriftsversjon finnes på våre nettsider) eller kontakte kontaktpunktet i landet der du bor. *EØS: Det europeiske økonomiske samarbeidsområdet</p>	Norsk
<p>Vigtig oplysning: Garantiplysninger til kunder i EØO* og Schweiz</p> <p>De kan finde detaljerede garantiplysninger om dette Yamaha-produkt og den fælles garantierindsats for EØO* (og Schweiz) ved at besøge det websted, der er angivet nedenfor (der findes en fil, som kan udskrives, på vores websted), eller ved at kontakte Yamahas nationale repræsentationskontor i det land, hvor De bor. * EØO: Det Europæiske Økonomiske Område</p>	Dansk

<p>Tärkeä ilmoitus: Takuutiedot Euroopan talousalueen (ETA)* ja Sveitsin asiakkaille</p> <p>Tämän Yamahan tuotteen sekä ETA-alueen ja Sveitsin takuuta koskevat yksityiskohtaiset tiedot saatte alla olevasta nettiosoitosta. (Tulostettava tiedosto saatavissa sivustollamme.) Voitte myös ottaa yhteyttä paikalliseen Yamaha-edustajaan. *ETA: Euroopan talousalue</p>	Suomi
<p>Ważne: Warunki gwarancji obowiązujące w EOG* i Szwajcarii</p> <p>Aby dowiedzieć się więcej na temat warunków gwarancyjnego tego produktu firmy Yamaha i serwisu gwarancyjnego w całym EOG* i Szwajcarii, należy odwiedzić wskazaną poniżej stronę internetową (Plik gotowy do wydruku znajduje się na naszej stronie internetowej) lub skontaktować się z przedstawicielstwem firmy Yamaha w swoim kraju. * EOG — Europejski Obszar Gospodarczy</p>	Polski
<p>Důležité oznámení: Záruční informace pro zákazníky v EHS* a ve Švýcarsku</p> <p>Podrobné záruční informace o tomto produktu Yamaha a záručním servisu v celém EHS* a ve Švýcarsku naleznete na níže uvedené webové adrese (soubor k tisku je dostupný na našich webových stránkách) nebo se můžete obrátit na zastoupení firmy Yamaha ve své zemi. * EHS: Evropský hospodářský prostor</p>	Česky
<p>Fontos figyelmeztetés: Garancia-információk az EGT* területén és Svájcban élő vásárlók számára</p> <p>A jelen Yamaha termékre vonatkozó részletes garancia-információk, valamint az EGT*-re és Svájcra kiterjedő garanciális szolgáltatás tekintetében keressék fel webhelyünket az alábbi címen (a webhelyen nyomtatható fájl is található), vagy pedig lépjen kapcsolatba az országában működő Yamaha képviselői irodával. * EGT: Európai Gazdasági Térség</p>	Magyar
<p>Oluline märkus: Garantiteave Euroopa Majanduspiirkonna (EMP)* ja Šveitsi klientidele</p> <p>Täpsemat teabe saamiseks selle Yamaha toote garantii ning kogu Euroopa Majanduspiirkonna ja Šveitsi garantiteeninduse kohta, külastage palun veebisaiti alljärgneval aadressil (meie saidil on saadaval printitav fail) või pöörduge Teie regiooni Yamaha esinduse poole. * EMP: Euroopa Majanduspiirkond</p>	Eesti keel
<p>Svarīgs paziņojums: garantijas informācija klientiem EEZ* un Šveicā</p> <p>Lai saņemtu detalizētu garantijas informāciju par šo Yamaha produktu, kā arī garantijas apkalpošanu EEZ* un Šveicā, lūdzim, apmeklējiet zemāk norādīto tīmekļa vietnes adresi (tīmekļa vietni ir pieejams drukājams fails) vai sazinieties ar jūsu valsti apkalpojošo Yamaha pārstāvnīcību. * EEZ: Eiropas Ekonomikas zona</p>	Latviešu
<p>Dėmesio: informacija dėl garantijos pirkėjams EEE* ir Šveicarijoje</p> <p>Ir reikia išsamioms informacijos apie šį „Yamaha“ produktą ir jo techninę priežiūrą visose EEE* ir Šveicarijoje, aplankykite mūsų svetainėje toliau nurodytą adresą (svetainėje yra spausdintinas failas) arba kreipkitės į „Yamaha“ atstovybę savo šalyje. * EEE – Europos ekonominė erdvė</p>	Lietuvių kalba
<p>Dôležité upozornenie: Informácie o záruke pre zákazníkov v EHP* a Švajčiarsku</p> <p>Podrobné informácie o záruke týkajúce sa tohto produktu od spoločnosti Yamaha a garancnom servise v EHP* a Švajčiarsku nájdete na webovej stránke uvedenej nižšie (na našej webovej stránke je k dispozícii súbor na tlač) alebo sa obráťte na zástupcu spoločnosti Yamaha vo svojej krajine. * EHP: Európsky hospodársky priestor</p>	Slovenčina
<p>Pomembno obvestilo: Informacije o garanciji za kupce v EGP* in Švici</p> <p>Za podrobne informacije o tem Yamahinem izdelku ter garancijskem servisu v celotnem EGP in Švici, obiščite spletno mesto, ki je navedeno spodaj (natisljiva datoteka je na voljo na našem spletnem mestu), ali se obrnite na Yamahinega predstavnika v svoji državi. * EGP: Evropski gospodarski prostor</p>	Slovenščina
<p>Важно съобщение: Информация за гаранцията за клиенти в ЕИП* и Швейцария</p> <p>За подробна информация за гаранцията за този продукт на Yamaha и гаранционното обслужване в паневропейската зона на ЕИП* и Швейцария или посетете посочения до-лу е сайт (на нашия уеб сайт има файл за печат), или се свържете с представителния офис на Yamaha във вашата страна. * ЕИП: Европейско икономическо пространство</p>	Български език
<p>Notificare importantă: Informații despre garanție pentru clienții din SEE* și Elveția</p> <p>Pentru informații detaliate privind acest produs Yamaha și serviciul de garanție Pan-SEE* și Elveția, vizitați site-ul la adresa de mai jos (fișierul imprimabil este disponibil pe site-ul nostru) sau contactați biroul reprezentanței Yamaha din țara dumneavoastră. * SEE: Spațiul Economic European</p>	Limba română

ADDRESS LIST

NORTH AMERICA

CANADA

Yamaha Canada Music Ltd.
135 Milner Avenue, Toronto, Ontario, M1S 3R1, Canada
Tel: +1-416-298-1311

U.S.A.

Yamaha Corporation of America
6000 Orangetherope Avenue, Buena Park, CA 90620, U.S.A.
Tel: +1-714-522-9011

CENTRAL & SOUTH AMERICA

MEXICO

Yamaha de México, S.A. de C.V.
Av. Insurgentes Sur 1647 Piso 9, Col. San José Insurgentes, Delegación Benito Juárez, México, D.F., C.P. 03900, México
Tel: +52-55-5804-0600

BRAZIL

Yamaha Musical do Brasil Ltda.
Rua Fidêncio Ramos, 302 – Cj 52 e 54 – Torre B – Vila Olímpia – CEP 04551-010 – São Paulo/SP, Brazil
Tel: +55-11-3704-1377

ARGENTINA

Yamaha Music Latin America, S.A., Sucursal Argentina
Olga Cossetini 1553, Piso 4 Norte, Madero Este-C1107CEK, Buenos Aires, Argentina
Tel: +54-11-4119-7000

PANAMA AND OTHER LATIN AMERICAN COUNTRIES/CARIBBEAN COUNTRIES

Yamaha Music Latin America, S.A.
Edif. Torre Banco General, Piso 7, Urbanización Marbella, Calle 47 y Aquilino de la Guardia, Ciudad de Panamá, República de Panamá
Tel: +507-269-5311

EUROPE

THE UNITED KINGDOM/IRELAND

Yamaha Music Europe GmbH (UK)
Sherbourne Drive, Tilbrook, Milton Keynes, MK7 8BL, U.K.
Tel: +44-1908-366700

GERMANY

Yamaha Music Europe GmbH
Siemensstrasse 22-34, 25462 Rellingen, Germany
Tel: +49-4101-303-0

SWITZERLAND/LIECHTENSTEIN

Yamaha Music Europe GmbH, Branch Switzerland in Thalwil
Seestrasse 18a, 8800 Thalwil, Switzerland
Tel: +41-44-3878080

AUSTRIA/BULGARIA/CZECH REPUBLIC/HUNGARY/ROMANIA/

SLOVAKIA/SLOVENIA

Yamaha Music Europe GmbH Branch Austria
Schleiergasse 20, 1100 Wien, Austria
Tel: +43-1-60203900

POLAND

Yamaha Music Europe GmbH Spz. o.o. Oddział w Polsce
ul. Wielicka 52, 02-657 Warszawa, Poland
Tel: +48-22-880-08-88

MALTA

Olimpus Music Ltd.
Valletta Road, Mosta MST9010, Malta
Tel: +356-2133-2093

PA50

NETHERLANDS/BELGIUM/LUXEMBOURG

Yamaha Music Europe Branch Benelux
Clarissenhof 5b, 4133 AB Vianen, The Netherlands
Tel: +31-347-358040

FRANCE

Yamaha Music Europe
7 rue Ambroise Croizat, Zone d'activités de Pariest, 77183 Croissy-Beaubourg, France
Tel: +33-1-6461-4000

ITALY

Yamaha Music Europe GmbH, Branch Italy
Via Tinelli N.67/69 20855 Gerno di Lesmo (MB), Italy
Tel: +39-039-9065-1

SPAIN/PORTUGAL

Yamaha Music Europe GmbH Ibérica, Sucursal en España
Ctra. de la Coruña km. 17,200, 28231 Las Rozas de Madrid, Spain
Tel: +34-91-639-88-88

GREECE

Philippos Nakas S.A. The Music House
19th km. Leof. Lavriou 190 02 Peania – Attiki, Greece
Tel: +30-210-6686168

SWEDEN/FINLAND/ICELAND

Yamaha Music Europe GmbH Germany filial Scandinavia
JA Wettergrensgata 1, 400 43 Göteborg, Sweden
Tel: +46-31-89-34400

DENMARK

Yamaha Music Denmark, Filial of Yamaha Music Europe GmbH, Tyskland
Generatorevej 8C, ST. TH., 2860 Soborg, Denmark
Tel: +45-44-92-49-00

NORWAY

Yamaha Music Europe GmbH German - Norwegian Branch
Grini Næringspark 1, 1332 Østerås, Norway
Tel: +47-6716-7800

CYPRUS

Yamaha Music Europe GmbH
Siemensstrasse 22-34, 25462 Rellingen, Germany
Tel: +49-4101-303-0

RUSSIA

Yamaha Music (Russia) LLC.
Room 37, entrance 7, bid. 7, Kievskaya street, Moscow, 121059, Russia
Tel: +7-495-626-5005

OTHER EUROPEAN COUNTRIES

Yamaha Music Europe GmbH
Siemensstrasse 22-34, 25462 Rellingen, Germany
Tel: +49-4101-3030

AFRICA

Yamaha Music Gulf FZE
JAFZA-16, Office 512, P.O.Box 17328, Jebel Ali FZE, Dubai, UAE
Tel: +971-4-801-1500

MIDDLE EAST

TURKEY

Yamaha Music Europe GmbH Merkezi Almanya Türkiye İstanbul Şubesi
Maslak Meydan Sodak, Spring Giz Plaza Bagimsiz Böl. No:3, Sariyer İstanbul, Turkey
Tel: +90-212-999-8010

OTHER COUNTRIES

Yamaha Music Gulf FZE
JAFZA-16, Office 512, P.O.Box 17328, Jebel Ali FZE, Dubai, UAE
Tel: +971-4-801-1500

ASIA

THE PEOPLE'S REPUBLIC OF CHINA

Yamaha Music & Electronics (China) Co., Ltd.
2F Yunhedasha, 1818 Xinzha-lu, Jingan-qu, Shanghai, China
Tel: +86-400-051-7700

INDIA

Yamaha Music India Private Limited
P-401, JMD Megapolis, Sector-48, Sohna Road, Gurgaon-122018, Haryana, India
Tel: +91-124-485-3300

INDONESIA

PT. Yamaha Musik Indonesia (Distributor)
Yamaha Music Center Bldg. Jalan Gen. Gatot Subroto Kav. 4, Jakarta 12930, Indonesia
Tel: +62-21-520-2577

KOREA

Yamaha Music Korea Ltd.
8F, Dongsung Bldg. 21, Teheran-ro 87-gil, Gangnam-gu, Seoul, 06169, Korea
Tel: +82-2-3467-3300

MALAYSIA

Yamaha Music (Malaysia) Sdn. Bhd.
No.8, Jalan Perbandaran, Kelana Jaya, 47301 Petaling Jaya, Selangor, Malaysia
Tel: +60-3-78030900

SINGAPORE

Yamaha Music (Asia) Private Limited
Block 202 Hougang Street 21, #02-00, Singapore 530202, Singapore
Tel: +65-6740-9200

TAIWAN

Yamaha Music & Electronics Taiwan Co., Ltd.
2F., No.1, Yuandong Rd., Banqiao Dist., New Taipei City 22063, Taiwan (R.O.C.)
Tel: +886-2-7741-8888

THAILAND

Siam Music Yamaha Co., Ltd.
3, 4, 15, 16th Fl., Siam Motors Building, 891/1 Rama 1 Road, Wangmai, Pathumwan, Bangkok 10330, Thailand
Tel: +66-2215-2622

VIETNAM

Yamaha Music Vietnam Company Limited
15th Floor, Nam A Bank Tower, 201-203 Cach Mang Thang Tam St., Ward 4, Dist.3, Ho Chi Minh City, Vietnam
Tel: +84-8-3818-1122

OTHER ASIAN COUNTRIES

OCEANIA

AUSTRALIA

Yamaha Music Australia Pty. Ltd.
Level 1, 80 Market Street, South Melbourne, VIC 3205, Australia
Tel: +61-3-9693-5111

COUNTRIES AND TRUST TERRITORIES IN PACIFIC OCEAN

Head Office/Manufacturer: Yamaha Corporation 10-1, Nakazawa-cho, Naka-ku, Hamamatsu, 430-8650, Japan
(For European Countries) Importer: Yamaha Music Europe GmbH Siemensstrasse 22-34, 25462 Rellingen, Germany

雅马哈乐器音响(中国)投资有限公司

上海市静安区新闻路1818号云和大厦2楼

客户服务热线：4000517700

公司网址：

制造商：雅马哈株式会社

制造商地址：日本静冈县滨松市中区中泽町10-1

进口商：雅马哈乐器音响(中国)投资有限公司

进口商地址：上海市静安区新闻路1818号云和大厦2楼

原产地：印度尼西亚

Manual Development Group

© 2017 Yamaha Corporation

Published 06/2017 改版 CRZC-C0

Printed in Indonesia

ZW72160