

Planar² Manual

Multi-Axis Vector Controller & Recorder

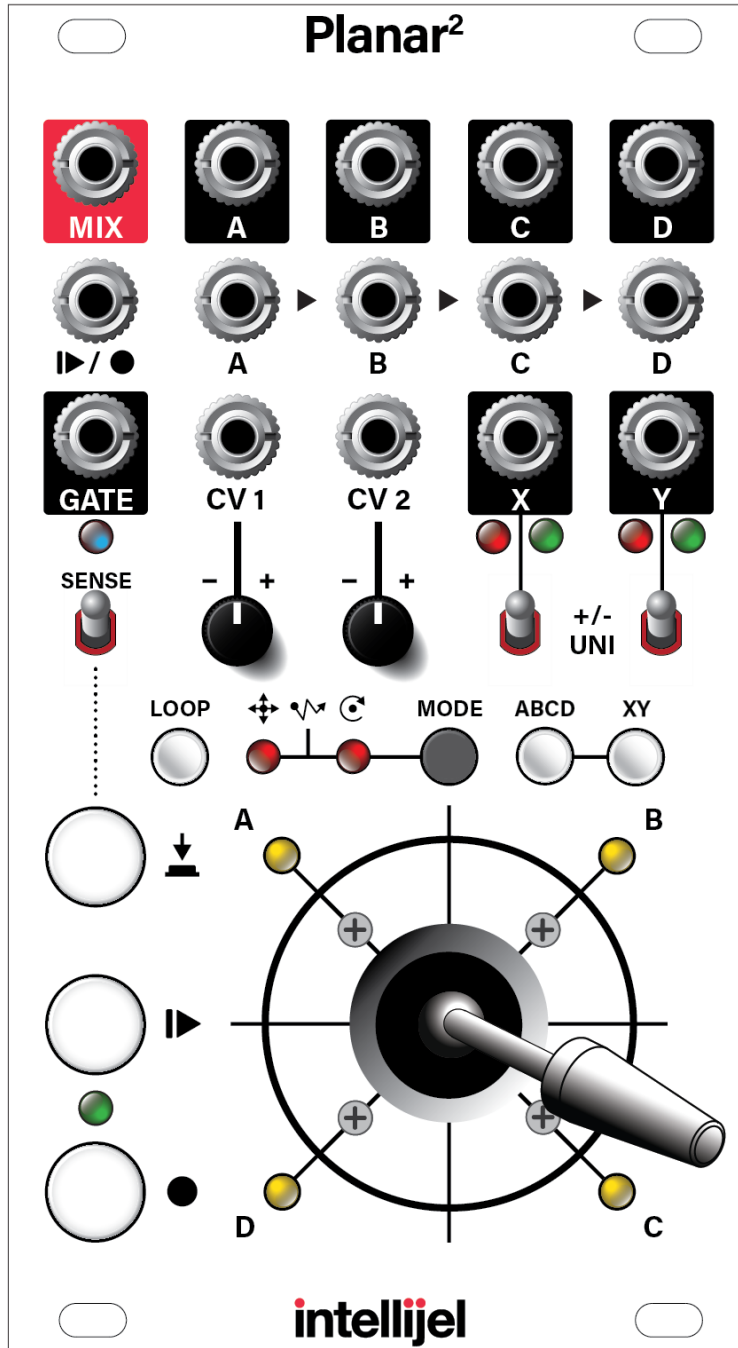

Table of Contents

[Table of Contents](#)

[Compliance](#)

[Installation](#)

[Installing Your Module](#)

[Overview](#)

[Features](#)

[A Cornucopia of Control](#)

[Front Panel](#)

[Inputs](#)

[Outputs](#)

[Controls](#)

[X/Y Control](#)

[GATE Generator](#)

[Quad Functions](#)

[Manual Quad Crossfader](#)

[Crossfading With Fewer Than Four Inputs](#)

[Quad Panner](#)

[Quad Router](#)

[Four Quadrant CV Generator](#)

[CV Gesture Recorder](#)

[Record & Play Joystick Movements and Gates without Metric Constraint](#)

[Syncing Record & Playback to an External Trigger](#)

[Using CV Inputs](#)

[Cartesian Automation](#)

[Polar Automation](#)

[Scan Automation](#)

[CV Automation Example](#)

[Calibration](#)

[Automatic Calibration](#)

[Manual Calibration](#)

[Calibration Testing](#)

[Firmware](#)

[Technical Specifications](#)

Compliance



This device complies with Part 15 of the FCC Rules. Operation is subject to the following two conditions: (1) this device may not cause harmful interference, and (2) this device must accept any interference received, including interference that may cause undesired operation.

Changes or modifications not expressly approved by Intellijel Designs, Inc. could void the user's authority to operate the equipment.

Any digital equipment has been tested and found to comply with the limits for a Class A digital device, pursuant to part 15 of the FCC Rules. These limits are designed to provide reasonable protection against harmful interference when the equipment is operated in a commercial environment. This equipment generates, uses, and can radiate radio frequency energy and, if not installed and used in accordance with the instruction manual, may cause harmful interference to radio communications.



This device meets the requirements of the following standards and directives:

EMC: 2014/30/EU

EN55032:2015 ; EN55103-2:2009 (EN55024) ; EN61000-3-2 ; EN61000-3-3

Low Voltage: 2014/35/EU

EN 60065:2002+A1:2006+A11:2008+A2:2010+A12:2011

RoHS2: 2011/65/EU

WEEE: 2012/19/EU

Installation

Intellijel Eurorack modules are designed to be used with a Eurorack-compatible case and power supply. We recommend you use Intellijel cases and power supplies.

Before installing a new module in your case, you must ensure your power supply has a free power header and sufficient available capacity to power the module:

- Sum up the specified +12V current draw for all modules, including the new one. Do the same for the -12 V and +5V current draw. The current draw will be specified in the manufacturer's technical specifications for each module.
- Compare each of the sums to specifications for your case's power supply.
- Only proceed with installation if none of the values exceeds the power supply's specifications. Otherwise you must remove modules to free up capacity or upgrade your power supply.

You will also need to ensure your case has enough free space (hp) to fit the new module. To prevent screws or other debris from falling into the case and shorting any electrical contacts, not leave gaps between adjacent modules, and cover all unused areas with blank panels. Similarly, do not use open frames or any other enclosure that exposes the backside of any module or the power distribution board.

You can use a tool like [ModularGrid](#) to assist in your planning. Failure to adequately power your modules may result in damage to your modules or power supply. If you are unsure, please [contact us](#) before proceeding.

Installing Your Module

When installing or removing a module from your case always turn off the power to the case and disconnect the power cable. Failure to do so may result in serious injury or equipment damage.

Ensure the 10-pin connector on the power cable is connected correctly to the module before proceeding. The red stripe on the cable must line up with the -12V pins on the module's power connector. The pins are indicated with the label -12V, a white stripe next to the connector, the words "red stripe", or some combination of those indicators.

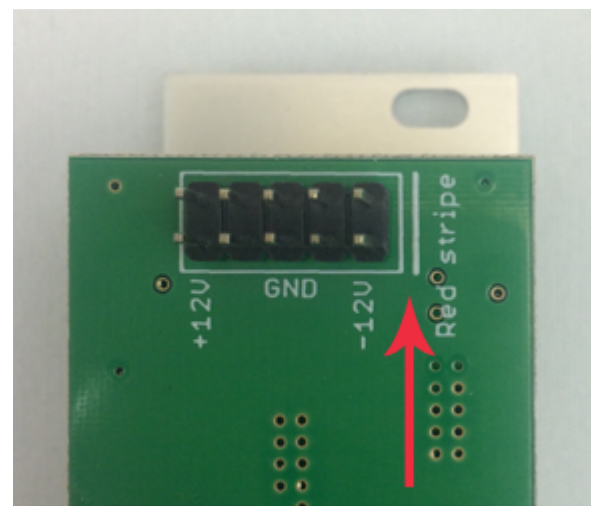

Most modules will come with the cable already connected but it is good to double check the orientation. Be aware that some modules may have headers that serve other purposes so ensure the cable is connected to the right one.

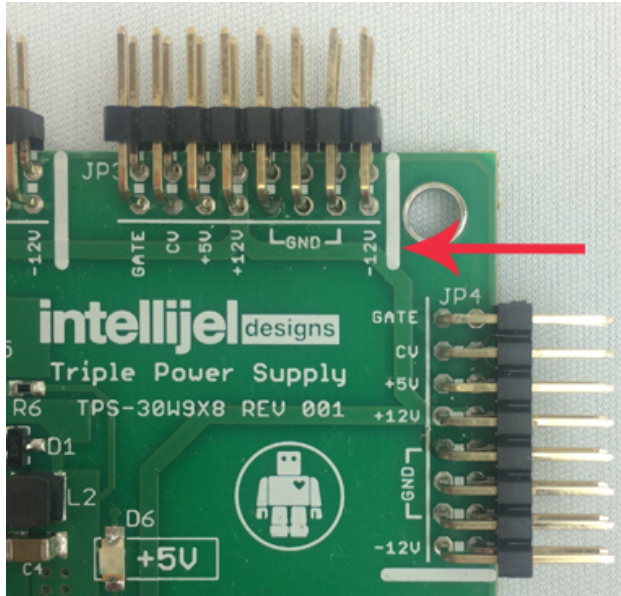

The other end of the cable, with a 16-pin connector, connects to the power bus board of your Eurorack case. Ensure the red stripe on the cable lines up with the -12V pins on the bus board. On Intellijel power supplies the pins are labelled with the label “-12V” and a thick white stripe:

If you are using another manufacturer’s power supply, check their documentation for instructions.

Once connected, the cabling between the module and power supply should resemble the picture below:

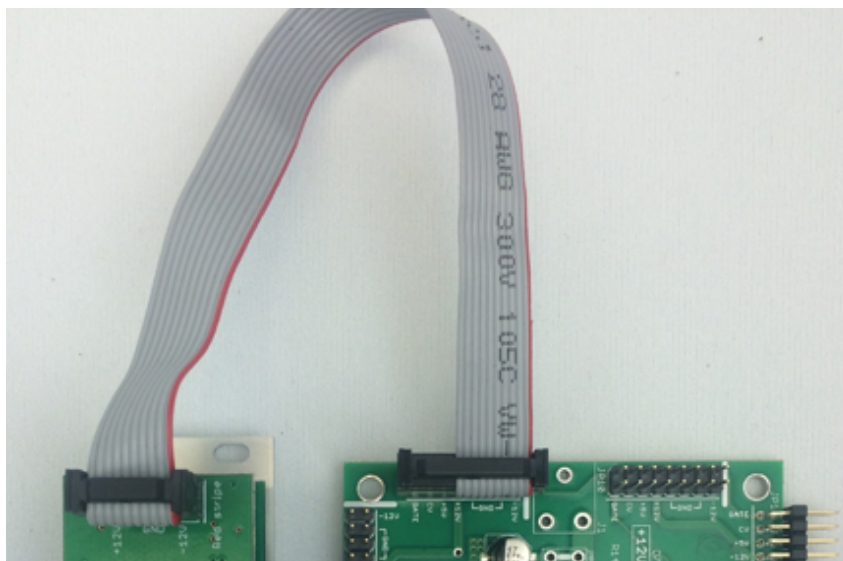

Before reconnecting power and turning on your modular system, double check that the ribbon cable is fully seated on both ends and that all the pins are correctly aligned. If the pins are misaligned in any direction or the ribbon is backwards you can cause damage to your module, power supply, or other modules.

After you have confirmed all the connections, you can reconnect the power cable and turn on your modular system. You should immediately check that all your modules have powered on and are functioning correctly. If you notice any anomalies, turn your system off right away and check your cabling again for mistakes.

Overview

With its smoothly responsive precision joystick, Planar² facilitates hands-on vector control of two entirely independent sets of outputs (quadrants A-D, and axis X/Y), plus the ability to capture and playback your gestures. Recording your joystick movements enables the creation of organic and complex envelopes, wild and wobbly LFOs, or extended sonic evolutions. It mixes, morphs, routes and pans audio inputs; triggers gates; outputs control voltages and is itself, CV-controllable. Planar² puts the 'joy' back in 'joystick,' and the 'fun' back in 'function generator.' Its multitasking and tactile interface makes it a flexible and unique control device, no matter what your musical genre.

Features

- Vector control of two independent sets of outputs: one quadrant-based (outputs A, B, C, D) and one dual-axis based (outputs X and Y).
- X/Y Controller: two-axis CV generator sends either unipolar (0V to +10V) or bipolar (-5V to +5V) signal out the X and Y outputs.
- Four Quadrant Controller: With nothing connected to inputs A-D, outputs A-D become joystick-controlled individual unipolar (0V to +10V) control voltage sources.
- Quad mixing & crossfading: Vector mixing and crossfading of four independent inputs (A, B, C, D) to either individual outputs or the mixed output.
- Quad panning: connect a mono source to Input A and use the joystick to pan it to any of the four outputs. Connect a stereo signal to Inputs A and C and pan it forward and backward in quadraphonic space.
- Quad routing: Send audio to Input A and patch outputs A-D to four different processors (i.e. VCF, wavefolder, delay, etc.), then use the joystick to dynamically route the signal through the different effects.
- Gate Generator: Generate gates either manually (by pressing the Manual Gate button) or automatically whenever the joystick is in motion.
- CV Gesture Recorder: Record joystick motions (including gates) to play back either as 1-shot complex function generators or as looped, LFO-like functions. Start time and length can sync to an external trigger, and punch-in/out recording is supported.
- External CV Inputs: In addition to its built-in joystick, Planar² has two CV inputs, which allows external CV control of quadrant outputs A-D and axis outputs X/Y. A mode switch alters how CV affects these outputs, allowing for some advanced automation techniques (such as circular and spinning motions) that would otherwise be difficult to automate.

A Cornucopia of Control

Planar²'s deceptively simple interface belies the tremendous depth of control that it offers. Over the next several pages we'll provide a detailed explanation of every feature, plus provide examples to showcase these features — which should give you numerous ideas of how to deploy Planar² in your own patches. We've grouped these discussions into different headings, which we'll explore individually:

- [Installation](#) - This section discusses how to install Planar² into a eurorack system, and apply power to the module.
- [Front Panel](#) - This section discusses each input, output, knob, button, light, switch and joystick on the Planar².
- [X/Y Control](#) - This section discusses using the Planar² as a two-axis dual CV controller.
- [GATE Generator](#) - This section discusses using the Planar² to generate gates — either manually with the push of a button, or automatically whenever the joystick is in motion.
- [Quad Functions](#) - This section discusses using the Planar² as a four-quadrant quad crossfader, panner, processing router and CV source.
- [CV Gesture Recorder](#) - This section discusses how to record your joystick motions (including gates), and play them back either as 1-shot complex function generators or as looped complex LFOs.
- [Using CV Inputs](#) - This section discusses how to process the two CV inputs and use external CV to modify the four quadrant outputs (A, B, C, and D) or the dual-axis X/Y outputs.

Even though this manual will discuss many of these features and operations independently, it's important to realize that many can be used simultaneously and in various combinations, resulting in some mind bending sonic manipulation.

Front Panel

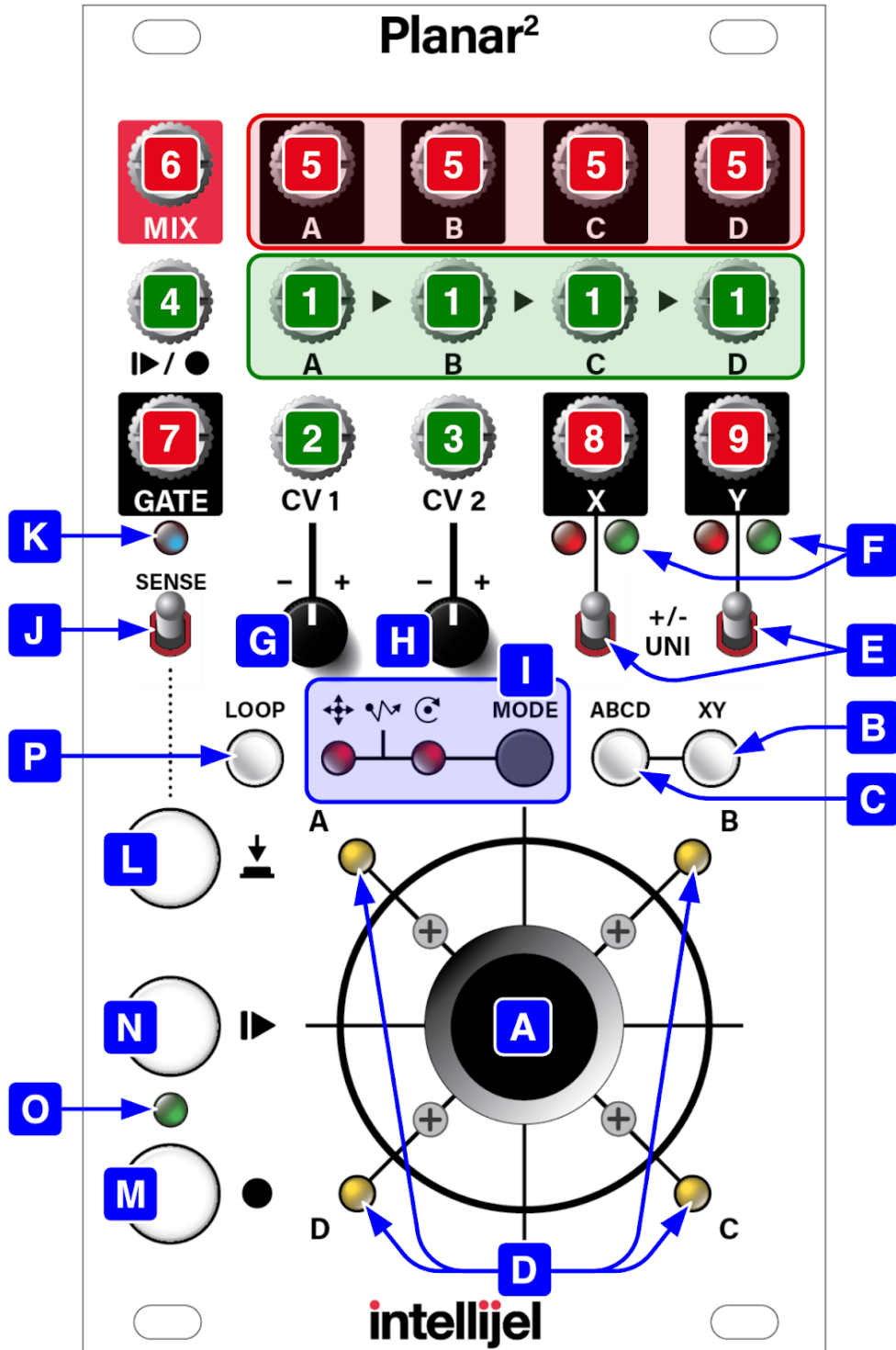

Inputs

In the previous illustration, the **GREEN** numerical labels indicate Planar² inputs.

1. A IN, B IN, C IN, D IN

Each of these jacks accepts an input signal, which the Planar² routes through an internal VCA, attenuates, and passes on to the correspondingly lettered output jacks [5], or sums to the **MIX** output [6] jack.

VCA levels may be adjusted and/or automated by any of the following means:

- the physical position of the joystick
- the recorded motion of the joystick
- any modulating signal present at the **CV 1** [2] and **CV 2** [3] inputs.

Each input jack is normalled to the one on its left. So if nothing is plugged into **IN B**, then it takes its feed from **IN A**; if nothing is plugged into **IN C**, then it takes its feed from **IN B**, etc.

2. CV 1 input

The first of two control voltage inputs, which Planar² can use to further define the values sent to either outputs **X** [8] and **Y** [9], or to outputs **A-D** [5] and **MIX** [6]. Each CV input has its own attenuverter [G] & [H] beneath it, and beneath those is a **MODE** switch [I], which changes the way Planar² interprets the incoming control voltage. CV control of Planar² is discussed thoroughly in [“Using CV Inputs.”](#)

3. CV 2 input

The second of two control voltage inputs, which Planar² can use to modify the values sent to outputs **X** and **Y**, or the relative levels of outs **A-D**.

4. TRIGGER input

-  If a cable is connected to this jack, Planar² synchronizes its recording and playback times to incoming triggers, enabling remote control of these operations. This is particularly useful if you patch in a divided clock, since it lets you create recordings that conform to a certain number of bars or beats, or quantize the playback time of an existing recording. If nothing is connected to this jack, recording and playback are started (or stopped) immediately upon pressing the **RECORD** or **PLAY** buttons. See [“Syncing Record & Playback to an External Trigger”](#) to learn more about triggering recording and playback functions.

Outputs

In the previous illustration, the **RED** numerical labels indicate Planar² outputs.

5. A OUT, B OUT, C OUT, D OUT

These are the direct outputs of the four internal VCAs, through which **Inputs A-D [1]** are routed. Output levels may be adjusted and/or automated by any of the following means:

- the physical position of the joystick
- the recorded motion of the joystick
- any modulating signal present at the **CV 1 [2]** and **CV 2 [3]** inputs.

If nothing is connected to **Inputs A-D**, then these outputs can be used as 0V-10V CV sources for controlling external modules, as described in [“Four Quadrant CV Generator.”](#)

6. MIX OUT

This is the summed output of the four internal VCAs, through which **Inputs A-D [1]** are routed. This output is particularly useful if you're employing Planar² as a 4-input mixer/crossfader, as described in [“Manual Quad Crossfader.”](#)

7. GATE OUT

This jack sends a gate signal out of Planar². You can trigger gates manually or automatically.

To trigger gates manually, press the **Manual Gate** button **[L]**. As long as the **Manual Gate** button is being depressed, the GATE OUT signal remains high.

Additionally, you can trigger gates automatically if the **SENSE** switch **[J]** is on (up position). This causes Planar² to send a high gate signal to the GATE OUT jack whenever the joystick is moved, and the gate will remain high for as long as it senses joystick movement. Planar² can record and playback gates generated by either technique, as described in [“CV Gesture Recorder.”](#)

8. X OUT

Outputs a voltage corresponding to the X-axis on Planar². The X-axis value is controlled by a number of factors, including: position of joystick along the X-axis; recorded value of joystick; CV input, CV mode; and state of the **XY** button **[B]**.

This jack outputs either unipolar voltages (0V to +10V) or bipolar voltages (-5V to +5V) depending on the position of the corresponding **Polarity switch [E]**. The **X/Y indicator LEDs [F]** display the polarity of this jack's output voltage (red = negative; green = positive), along with the absolute voltage level (brighter = more voltage).

9. Y OUT

This jack performs identically to the **X OUT** jack (described above), but outputs Y-axis values, rather than X-axis.

Controls

In the previous illustration, the **BLUE** alphabetical labels indicate Planar² controls.

A. Joystick

The joystick allows you to directly control both the **X [8]** and **Y [9]** control voltage outputs, and the **A, B, C, D [5]** and **MIX [6]** outputs — either separately or together, depending on the state of the **XY [B]** and **ABCD [C]** buttons. Joystick movements can be recorded and played back using the **RECORD [M]** and **PLAY [N]** buttons, and the joystick may generate gate signals when moved (if the **SENSE [J]** switch is in the 'up' position).

B. XY button

This button controls the various ways in which the joystick, internal recording and CV inputs all affect the **X [8]** and **Y [9]** control voltage outputs. The button has three states:

- LIT = CV IN + (JOYSTICK or RECORDING)

When the **XY button** is lit, the joystick sends its position to the **X** and **Y** outs. If you are playing back your recorded joystick movements, then the recorded values are sent to the **X** and **Y** outputs instead of the joystick's actual position. Any input present at the **CV 1** and **CV 2** jacks is added to the joystick/recorded values per the setting of the **MODE** button & indicator LEDs [I].

- FLASHING = JOYSTICK

When the **XY button** is flashing, only the joystick's present location is sent to the **X** and **Y** outs. Any recorded joystick movements are ignored as are the two CV inputs.

- UNLIT = CV IN

When the **XY button** is not lit, both the joystick position and any recording of the joystick movements is disabled, and the joystick is 'virtually' centered, sending a static voltage to the **X** and **Y** outputs. CV input is active, allowing external control of the **X** and **Y** outputs.

Accessing these three states involves either quickly-pressing the **XY button** or pressing-and-holding it for 1 second. Specifically:

- Quick-press the **XY button** to toggle it 'on' and 'off'.

If the **XY button** is on (either steadily lit or flashing), quick-pressing the button turns it off. If the **XY button** is off, quick-pressing it turns it on and sets it to the LIT state.

- Press-hold the **XY button** to switch between the two 'on' states (LIT and FLASHING).

If the **XY button** is on (either lit or flashing), press-holding the button toggles between the LIT and FLASHING states. If the **XY button** is off, press-holding the button turns it on and sets it to the FLASHING state.

*NOTE: Planar² checks the status of the **XY button** approximately every 30 seconds, and if it's changed, writes the new state to memory. This ensures the module powers on with the **XY button** in the same state as you last used it.*

C. ABCD button

This button behaves exactly the same as the **XY button [B]**, described above, only it governs how outputs **A, B, C, D [5]** and **MIX [6]** are affected by the joystick, a recording, or the CV inputs.

*NOTE: As with the **XY button**, Planar² checks the status of the **ABCD button** approximately every 30 seconds, and if it's changed, writes the new state to memory.*

D. Quadrant indicator LED (x4)

These LEDs indicate the voltage level present at each of the four quadrants, and thus the relative levels of the **A-D outputs [5]** (or the relative level of each in the **MIX [6]** output).

E. Polarity switches

These are 2-position switches that set the polarity of the **X OUT [8]** and **Y OUT [9]** control voltages. There are two of these switches — one for each CV output (**X** and **Y**). Specifically:

- **UNI**: In this position, moving the joystick along the corresponding access generates voltages between 0V and +10V.
- **+/-**: In this position, moving the joystick along the corresponding access generates voltages between -5V and +5V.

*NOTE: The position of this switch also affects **X** and **Y** outputs of any previously recorded joystick movements or the values summed with **CV 1** and **CV 2**.*

F. X/Y indicator LEDs

These LEDs indicate both the level and polarity of the voltage being sent from the **X OUT [8]** and **Y OUT [9]** jacks. Negative voltages light the red LED and positive voltages light the green LED. The LEDs glow brighter as the absolute voltage level increases.

G. CV 1 Input attenuverter

Scales and/or inverts the incoming voltage at the **CV 1 input [2]**. When the attenuverter is fully clockwise, Planar² uses the full range of voltages present at **CV 1** to affect the relative values of quadrants A-D and/or axis X/Y. Rotating the attenuverter toward “noon” (straight up) decreases the amount of **CV 1**'s effect, and at “noon” it has no effect at all. Rotating the attenuverter further clockwise inverts the voltage, until the maximum inverse effect is applied when the attenuverter is fully counterclockwise.

H. CV 2 Input attenuverter

Scales and/or inverts the incoming voltage at the **CV 2 input [3]** as described above.

I. MODE button & indicator LEDs

Press the **MODE button** to cycle through the three ways in which the **CV 1 [2]** and **CV 2 [3]** inputs may influence the level of outputs **A-D [5]**, their relative levels in the **MIX OUT [6]**, or the **X [8]** and **Y [9]** outputs. Specifically:



Cartesian Mode: If the left LED is lit, **CV 1** and **CV 2** operate in cartesian mode. This means **CV 1** maps to the *X-axis* and **CV 2** maps to the *Y-axis*. For more information, see [Cartesian Automation](#).



Polar Mode: If the right LED is lit, **CV 1** and **CV 2** operate in polar mode. This means **CV 1** maps to *rotation* and **CV 2** maps to *radius*. This allows you to easily create spinning or swirling effects using only simple waveforms (such as a sawtooth wave to create a 360° spin). For more information, see [Polar Automation](#).

IMPORTANT: By default CV 2 (and thus, the radius) is set to 0V, meaning you won't hear or see the effect of CV 1 unless you patch a voltage other than 0V into CV 2.



Scan Mode: If both LEDs are lit, **CV 1** and **CV 2** operate in scan mode. Scan mode requires the presence of a joystick recording, which the CV inputs then control. Specifically, **CV 1** locates a precise point along the recording's time axis, while **CV 2** controls the linearity of that axis. This lets you scrub either forward or backward through any portion of a CV recording. For more information, see [Scan Automation](#).

*NOTE 1: CV input affect the Planar² outputs only if the corresponding output buttons are LIT or OFF. If an **XY [B]** or **ABCD [C]** button is FLASHING, then CV input is ignored for that particular set of outputs.*

*NOTE 2: Planar² checks the **MODE** status approximately every 30 seconds, and if it's changed, writes the new state to memory. This ensures the module powers on in the same mode as you last used it.*

J. SENSE switch

If this switch is on (up position), then Planar² senses movement of the joystick, and sends a high gate signal to its **GATE OUT** jack **[7]** whenever the joystick is in motion. When you stop moving the joystick, the gate goes low. This is particularly useful for triggering external envelopes/VCA's in synchronicity with joystick movements.

Note that when **SENSE** mode is on, you can still create gates manually using the **Manual Gate** button **[L]**.

K. GATE out indicator LED

This indicator light blue whenever a high gate signal is being sent out Planar².

L. Manual Gate button



Pressing this button sends a gate signal to the **GATE OUT [7]** jack. The gate signal remains high for as long as the **Manual Gate button [L]** is held down.

When recording, Planar² records all your manual gate presses and plays them back accordingly.

M. RECORD button



Use the **RECORD** button to record joystick movements, which you can then play back as a loop (great for using the joystick to create complex LFOs) or as a one-shot (ideal for using the joystick to design complex envelopes). You can record for approximately 30s, and with a resolution that smoothly and accurately captures all the subtle nuances of your joystick movements.

How you operate the **RECORD** button depends on what (and how) you wish to record:

- **UNSYNCED RECORDING:** If nothing is connected to the **TRIGGER [▶ / ●] input [4]**, then recording begins immediately after you press and release the **RECORD** button. The **RECORD** button glows red to indicate you're recording. Recording stops (and the red light goes out) after you press and release the **RECORD** button a second time. Alternately, you can stop recording by pressing and releasing the **PLAY button [N]**, which not only stops recording but causes it to play back instantly.
- **SYNCED RECORDING:** You can synchronize recording to an external signal by using the **TRIGGER [▶ / ●] input [4]**. In this instance, recording does not start (or stop) the instant you release the **RECORD** button, but is instead started (or stopped) at the arrival of the next trigger signal. In other words, when synchronized to the **TRIGGER** input, pushing the **RECORD** button arms the recording, while the trigger signal starts the recording. An armed **RECORD** button rapidly flashes red while waiting for the trigger signal.

With this feature you can, for example, send the output of a clock divider to the **TRIGGER** input, thus ensuring your recordings conform to some metrical length.

- **PUNCH-IN/OUT RECORDING:** If you press-and-hold-down the **RECORD** button while an existing recording plays back, you will overwrite a section of that recording for as long as you continue to depress the **RECORD** button. When you release the **RECORD** button, punch-in recording stops.

This allows you to make small edits to existing recordings or to evolve a recording over the course of a song.

*NOTE: To erase a recording entirely, press and hold the **PLAY** button for over one second.*

For more information about recording, see [CV Gesture Recorder](#), later in this manual.

N. PLAY button



Press this button to start and stop playback of your recorded joystick movements.

The **PLAY** button has four visual states:

- **UNLIT**: If the button is not lit, it means there is no recording, and therefore nothing to play back. Pressing an unlit **PLAY** button does nothing.
- **PULSING**: If the button is pulsing, it means there is a recording in memory, but that it's not currently playing. If you press a pulsing **PLAY** button with nothing plugged into the **TRIGGER [▶ / ●] Input [4]**, then playback will begin immediately and the **PLAY** button will light solid.
- **LIT**: If the button is lit solid, it means the recorded joystick movements are currently playing back. You can stop playback at any time by pressing the **PLAY** button. Once stopped, the **PLAY** button pulses. Note that a recording will play back either in 1-shot mode or will loop in one of two modes, depending on the state of the **LOOP** button **[P]**.

*NOTE: Press and hold a lit **PLAY** button for over one second to erase the internal recording completely.*

- **RAPID FLASH**: A rapidly flashing **PLAY** button indicates that the **PLAY** button has been pressed, but that Planar² is waiting for a trigger signal at its **TRIGGER [▶ / ●] Input [4]**. Once the trigger is received, Planar² plays the recording and lights the **PLAY** button solid.

O. TRIGGER indicator LED

This LED lights briefly each time Planar² receives a signal at its **TRIGGER [▶ / ●] input jack [4]**. This is particularly useful if you're syncing your recorded joystick motions with an external clock, since it gives you a visual indication of the rhythm and will help you time the start and stop points of your recording.

P. LOOP Button

This button controls whether or not your joystick recording will loop and, if so, how it loops in the presence of external triggers. The button has three states:

- **UNLIT**: If the **LOOP** button is unlit, then your recorded joystick movements will play only once when you press the **PLAY** button [N] to start playback. This makes Planar² work as a complex function generator.

If you're using the **TRIGGER** [▶/●] Input [4], then pressing the **PLAY** button arms playback and the first trigger will play back the recording one time. If you want to playback the recording again, you must press the **PLAY** button to re-arm playback and then send it a trigger.

- **LIT**: If the **LOOP** button is lit, then your recorded joystick movements will loop continuously when you press the **PLAY** button [N] to start playback. Playback will stop when you hit the **PLAY** button again.

If you're using the **TRIGGER** [▶/●] Input [4], then pressing the **PLAY** button arms playback and the first trigger will start playing back the recording in a loop. The recording will loop continuously until you press the **PLAY** button again to stop it. While a loop is playing, each subsequent trigger restarts the loop at the beginning. For example, if you have a 4-bar recording, but send triggers to Planar² that are spaced 2-bars apart, then only the first two bars will loop (since the loop is retriggered every 2-bars). Conversely, if you have a 3-bar recording and your triggers are spaced 4-bars apart, Planar² plays all three bars then loops back to the beginning to play the first bar — at which point the next trigger causes the loop to reset to the first bar again (meaning the loop plays bars 1+2+3+1+1+2+3+1+1+2+3... etc).

- **FLASHING**: If the **LOOP** button is flashing, then your recorded joystick movement will play once when you press the **PLAY** button and then automatically re-arm playback as Planar² waits for a new trigger at its **TRIGGER** [▶/●] Input [4].

If you're using the **TRIGGER** [▶/●] Input [4], then pressing the **PLAY** button arms playback and the first trigger will play back the recording one time, then wait for a new trigger to replay the recording. Each time Planar² gets a trigger it plays the recording. So if you have a 4-bar recording, but send triggers to Planar² that are spaced 2-bars apart, only the first two bars will loop (exactly as with the LIT state). However, if you have a 3-bar recording and send triggers every 4-bars, then Planar² will play through all three bars once, pause while it waits for the next trigger, then play the three bars again. In this situation, a flashing **LOOP** button would play: 1+2+3+rest+1+2+3+rest... etc. Contrast this to the playback pattern of the LIT **LOOP** button state.

If you're not using the **TRIGGER [▶/●] Input [4]**, then a flashing **LOOP** button behaves the same as an unlit **LOOP** button.

Accessing these three states involves either quickly-pressing the **LOOP button** or pressing-and-holding it for 1 second. Specifically:

- Quick-press the **LOOP button** to toggle it 'on' and 'off'.

If the **LOOP button** is on (either steadily lit or flashing), quick-pressing the button turns it off. If the **LOOP button** is off, quick-pressing it turns it on and sets it to the LIT state.

- Press-hold the **LOOP button** to switch between the two 'on' states (LIT and FLASHING).

If the **LOOP button** is on (either lit or flashing), press-holding the button toggles between the LIT and FLASHING states. If the **LOOP button** is off, press-holding the button turns it on and sets it to the FLASHING state.

X/Y Control

In its most simple operating scenario, the Planar² joystick acts as a two-axis CV generator. Moving the joystick along the X-axis generates control voltages from the **X OUT** jack, while moving the joystick along the Y-axis generates control voltages from the **Y OUT** jack. You can switch the polarity of each axis between unipolar (0V to +10V) and bipolar (-5V to +5V).

To use the joystick to generate control voltages from the X and Y outputs:

1. Connect the **X OUT** jack to a CV input on some module you wish to control.

In this example, we'll connect the Planar² **X OUT** jack to the **FM2** input on a *Polaris* filter, and we'll set the *Polaris*' **FM2 attenuverter** fully clockwise.

2. Connect the **Y OUT** jack to a CV input on some module you wish to control.

In this example, we'll connect the Planar² **Y OUT** jack to the **Q IN** jack on a *Polaris* filter, and we'll set the *Polaris*' **Q attenuator** to roughly the noon position.

3. If the **XY** button on the Planar² is not lit, quickly press it to turn on the XY outputs and light the button. For this example, it doesn't matter whether the **XY** button is flashing or lit steady — either state enables the joystick to control the **X** and **Y** outputs.
4. For each output (**X** and **Y**), use the corresponding **polarity switch** to define the joystick's voltage control range. Specifically:

UNI: In the **UNI** position, moving the joystick along the corresponding access generates voltages between 0V and +10V, which means any control voltages generated by the joystick will be added to the baseline value of the parameter you're modulating. So in this example, setting X's polarity to **UNI** would cause the joystick to only increase the *Polaris*' **Cutoff** frequency above whatever value you've set on its panel.

+/-: In the **+/-** position, moving the joystick along the corresponding access generates voltages between -5V and +5V. This means, when the joystick is right of the center point

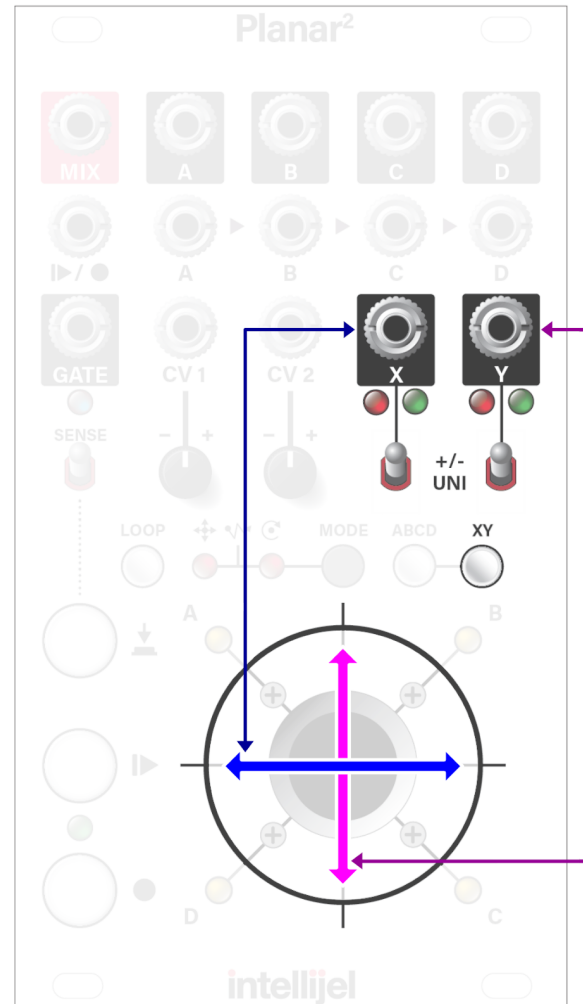

(X) or above it (Y), it will add to the baseline value of the parameter you're modulating. But if the joystick is left of the center point (X) or below it (Y), it will subtract from the baseline value of the parameter you're modulating. So in this examples, setting X's polarity to +/- would cause the joystick to increase the *Polaris*' **Cutoff** frequency whenever the joystick is right of center, and it would decrease the *Polaris*' **Cutoff** frequency whenever it was left of center.

NOTE: You can set the **X** and **Y** outputs to different polarities, allowing for some rather complex and nuanced modulation control.

5. Wiggle the joystick and enjoy the results.

As you move the joystick, notice that the pair of indicator LEDs beneath both the **X** and **Y** outputs vary in intensity. These LEDs indicate both the level and polarity of the voltage being sent from the **X** and **Y** jacks. Negative voltages light the red LED and positive voltages light the green LED. The LEDs glow brighter as the absolute voltage level increases. Obviously, any axis set to **UNI** polarity will generate only positive voltages, and thus light only the green LED.

See [CV Gesture Recorder](#) to learn how to record and playback your joystick movements.

GATE Generator

Tangentially related to the joystick is the gate function. Specifically if the **SENSE** switch is turned on (up position) and the joystick is in motion, then Planar² sends a +5V gate signal to its **GATE OUT** jack for as long as you're moving the joystick. In addition, you may use the **Manual Gate** button to create gates manually. Manual gates are possible regardless of the position of the **SENSE** switch.

To use the joystick to generate gates from the GATE OUT jack:

1. Connect the **GATE OUT** jack to a gate input on some module you wish to control.

In this example, we'll connect the Planar² **GATE OUT** jack to a trigger input on a *Quadra*, and we'll set the *Quadra*'s **Mode** switch to the center (**ASR**) position.

2. Make sure the Planar² **SENSE** switch is in the up position.

This enables the joystick to generate gates. If this switch is in the down position, only manually generated gates (using the **Manual Gate** button) are possible.

3. Move the joystick.

As long as the joystick is in motion, it will generate a high gate voltage, which Planar² sends out its **GATE OUT** jack. When you stop moving the joystick, the gate voltage falls to zero. The built-in **Gate Out Indicator LED** (located immediately below the **GATE OUT** jack) provides visual indication of the gate signal.

In our *Quadra*-based example, moving the joystick sends a trigger signal to the *Quadra*, which opens at a rate set by its **ATTACK** knob. Then, as long as the joystick is in motion, the *Quadra*'s envelope remains open (because it's in **ASR** mode). When you stop moving the joystick, the *Quadra*'s envelope decays at a rate set by its **DECAY** knob.

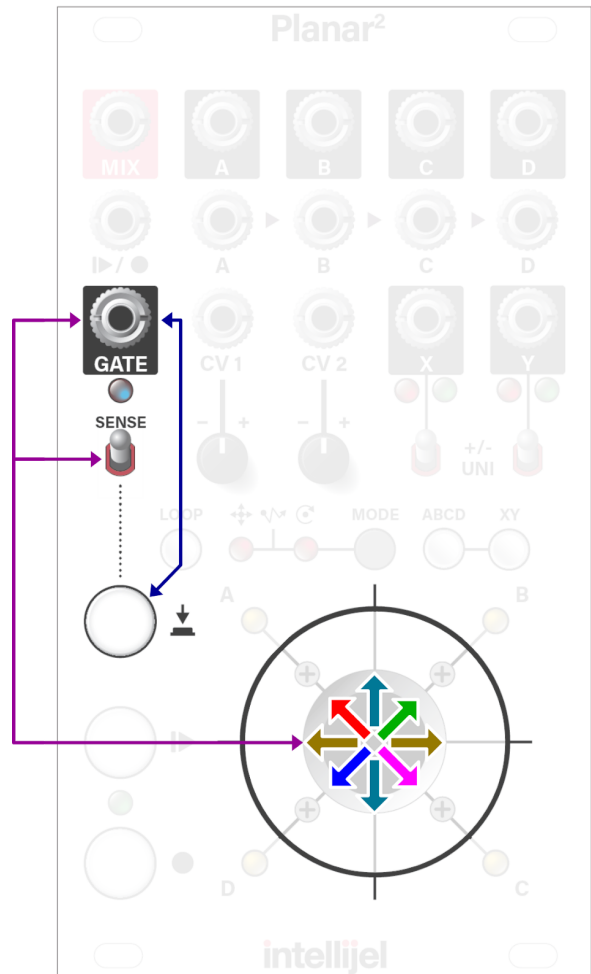

To generate gates without using the joystick:

You can always use the **Manual Gate** button to generate a gate regardless of the **SENSE** switch position. To do so:

1. Connect the **GATE OUT** jack to a gate input on some module you wish to control.
2. Press the **Manual Gate** button to generate a gate. As long as the button is held down, a high gate voltage (+5V) is sent to the Planar² **GATE OUT** jack (as indicated by the built-in **Gate Out Indicator LED**).
3. Manually-generated gates are completely independent of the joystick, and can be used to trigger and gate other signals or events that have nothing to do with the movement of the joystick.

Gate signals can be recorded and played back. See [CV Gesture Recorder](#) to learn how to record and playback your joystick movements.

Quad Functions

In this section, you'll learn how to use Planar² as a quad crossfader, panner, processing router, and four-quadrant CV generator. You'll also learn how to automate these functions using the **CV 1** and **CV 2** inputs.

Manual Quad Crossfader

Use this technique to dynamically mix and crossfade between as many as four inputs.

1. Plug up to four different audio sources into inputs **A**, **B**, **C** and **D**.

You may use fewer inputs you wish.

See the [“Crossfading With Fewer Than Four Inputs”](#).

2. Plug the **MIX** output into your sound system.
3. If the **ABCD** button isn't already lit, press it to turn on the ABCD outputs and light the button. For this example, it doesn't matter whether the **ABCD** button is flashing or lit steady — either state enables the joystick to control the **ABCD** VCA levels.

4. Wiggle and waggle the joystick. As you do, you'll hear the relative balance of the four audio inputs change as they seamlessly crossfade into one another.

Notice that the joystick is divided into four quadrants, with Quadrant A in the upper-left, B in the upper-right, C in the lower-right, and D in the lower-left. As you move the joystick, the relative intensities of the corresponding Quadrant LEDs change to reflect the amplitude. The brighter the LED, the greater the signal level present at that quadrant's output.

You can record your joystick movements and play back the crossfades as either a one-shot complex 'envelope' or as a loop (like a complex LFO), described in [“CV Gesture Recorder.”](#) You can also control the crossfades remotely using the two CV inputs, as described in [“Using CV Inputs.”](#)

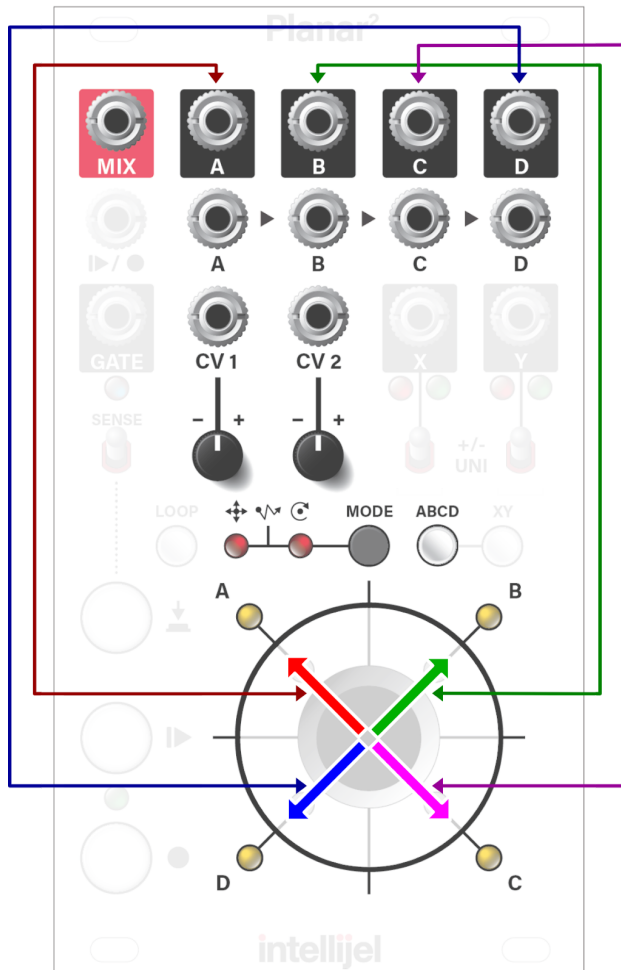

Crossfading With Fewer Than Four Inputs

Planar² normals its four inputs in a cascading fashion. That is, if if nothing is plugged into **IN B**, then it's normalled to **IN A**; If nothing is plugged into **IN C**, then it's normalled to **IN B**, and so on down the chain.

IN A is not normalled to anything, so if nothing is plugged into it, then no signal feeds its VCA.

This arrangement offers numerous usage scenarios, such as the ability to create single-, dual-, and three-channel crossfades as detailed below.

To create a single-channel fade:

1. Plug an audio source into **IN C**.
2. Plug the **MIX** output into your sound system.
3. If the **ABCD** button isn't already lit, press it to turn on the ABCD outputs and light the button (either the flashing or steady lit states will do). When the **ABCD** button is lit, the joystick can control the ABCD VCA levels.
4. Move the **joystick** up and down — as the joystick rises, the sound fades out. As the joystick falls, the sound grows louder.

Explanation: Because nothing is plugged into **IN A**, nothing feeds Quadrant A's VCA. And since **IN B** is normalled to **IN A**, then no signal feeds into **IN B** either. The audio source patched into **IN C** feeds Quadrant C, and since nothing is plugged into **IN D**, it's input is normalled to **IN C**.

You don't have to use **IN C**. If you use **IN B**, then the sound will fade out only when the joystick points to Quadrant A. If you use **IN D**, then the sound will fade out whenever the joystick points to Quadrants A, B or C. However, if you use **IN A**, then no fading will occur (since the normalling architecture means that a single signal fed into **IN A** will feed the remaining three inputs if nothing is connected to them).

To create a dual-channel crossfade:

1. Plug one audio source into **IN A** and the other into **IN C**.
2. Plug the **MIX** output into your sound system.
3. If the **ABCD** button isn't already lit, press it to turn on the ABCD outputs and light the button (either the flashing or steady lit states will do). When the **ABCD** button is lit, the joystick can control the ABCD VCA levels.
4. Move the **joystick** up and down — as the joystick rises, you'll hear more of **IN A** in the mix. As the joystick falls, you'll hear more of **IN C**.

Explanation: With nothing connected to IN B, it's normalled to IN A. This means the signal present at IN A feeds both Quadrant A and B's VCAs. Similarly, with nothing connected to IN D, it's normalled to IN C, meaning the signal present at IN C feeds both Quadrant C and D. Therefore, whenever the joystick rises, you hear more of Quadrants A and B — both of which have the same signal. And as the joystick falls, you hear more of Quadrants C and D — both of which also have the same signal.

You don't have to use **IN A** and **IN C**. For example, if you used **IN A** and **IN D**, then (because **IN B** and **IN C** are normalled to **IN A**), pointing the joystick to Quadrants A, B or C would all result in you hearing IN A in the mix. Crossfading to IN D would occur only if you moved the joystick toward Quadrant D.

To create a three-channel crossfade:

If you've been following along, you probably already know how to do this. But we'll run through an example anyway:

1. Plug one audio source into **IN A** and the others into **IN C** and **IN D**.
2. Plug the **MIX** output into your sound system.
3. If the **ABCD** button isn't already lit, press it to turn on the ABCD outputs and light the button (either the flashing or steady lit states will do). When the **ABCD** button is lit, the joystick can control the ABCD VCA levels
4. Move the **joystick** up and down — when the joystick points toward either Quadrants A or B, you'll hear more of **IN A** in the mix. Moving the joystick toward Quadrant C will bring more of **IN C** into the mix, while moving the joystick toward Quadrant D will bring more of **IN D** into the mix.

Again, you're free to use whichever inputs you like, depending on which signal is more important or how you wish to map your joystick movements to the crossfades.

Quad Panner

If you're using your eurorack system in a surround sound or quadraphonic system, you can use Planar² to move any signal left, right, forward or backward throughout the quadraphonic field. Specifically:

1. Plug an audio source into **IN A**.
2. Connect **OUTS A-D** to the four channels of your quadraphonic sound system.
Specifically, connect **OUT A** to the front-left channel; **OUT B** to the front-right; **OUT C** to the rear-right; and **OUT D** to the rear-left.
3. If the **ABCD** button isn't already lit, press it to turn on the ABCD outputs and light the button (either the flashing or steady lit states will do). When the **ABCD** button is lit, the joystick can control the ABCD VCA levels
4. Move the **joystick**.
As you move it left and right, the audio signal present at **IN A** pans left and right in the quadraphonic space, and as you move the joystick up and down, the audio signal present at **IN A** moves forward and backward.

Quad Router

This technique is similar to the Quad Panner (discussed above). But instead of dynamically routing one signal to four different speakers, you route one signal to four different processors. For example, you might run the signal through Morgasmatron's lowpass filter if the joystick is in Quadrant A; a μ Fold if the joystick is in Quadrant B, Polaris' phaser in Quadrant C, and Rainmaker's resonant comb filter in Quadrant D. Moving the joystick around crossfades between the four different effects.

1. Plug an audio source into **IN A**.
2. Connect **OUTS A-D** to four different signal processors. For example, connect **OUT A** to Morgasmatron; **OUT B** to a μ Fold; **OUT C** to a Polaris; and **OUT D** to a Rainmaker.
3. Connect the outputs of the four signal processors to a mixer.
4. If the **ABCD** button isn't already lit, press it to turn on the ABCD outputs and light the button (either the flashing or steady lit states will do). When the **ABCD** button is lit, the joystick can control the ABCD VCA levels
5. Move the **joystick**. As you move it toward each of the four quadrants (A, B, C and D), you'll hear more of the effect assigned to that quadrant and less of the others, allowing you to dynamically mix and morph between processed sounds.

Four Quadrant CV Generator

With nothing connected to inputs **A-D**, you can use outputs **A-D** as individual control voltage sources. Unlike X/Y control, outputs **A-D** are strictly unipolar (0V to +10V).

To use the joystick to generate control voltages from outputs **A, B, C** and **D**:

1. Connect the **A OUT** jack to a CV input on some module you wish to control.
2. Connect outputs **B, C** and **D** to other CV inputs on the same or different modules.
3. If the **ABCD** button isn't already lit, press it to turn on the ABCD outputs and light the button (either the flashing or steady lit states will do). When the **ABCD** button is lit, the joystick can control the ABCD VCA levels
4. Move the **joystick** around.

Unlike X/Y control, which transmits two CV values (X and Y) based on the joystick's relative position along the X or Y-axis, this mode transmits four CV values (A, B, C and D) based on the joystick's relative positioning toward one of the four diagonal quadrants. The brightness of the four Quadrant indicator LEDs represents the current voltage value being sent to each output. The brighter the LED, the higher the voltage.

You can also use the **CV 1** & **CV 2** inputs to control the voltage sent to outputs **A-D**. CV control of all quadrant functions is discussed in [“Using CV Inputs.”](#)

CV Gesture Recorder

This section discusses how to record your joystick motions (including gates), and play them back either as 1-shot complex envelope-like functions or as looped, LFO-like functions.

You can synchronize a recording's start time and length to an external trigger for metric rigidity, or you can record *a capriccio* without metric constraint. You can punch-in/out of an existing recording, and you can use your recording to control either the ABCD quadrant outputs, the XY outputs, both, or neither.

Let's get started.

Record & Play Joystick Movements and Gates without Metric Constraint

In this section we'll look at the basics of recording and playing back your joystick movements without synchronizing them to an external trigger. Planar² allows you to record up to 30s of high-resolution joystick movements.

To record your joystick movements:

1. First, decide which outputs you want to control with your joystick recording.

If you wish to control the **A**, **B**, **C**, **D** and **MIX** outputs, then the **ABCD** button needs to be lit. If it's off, press it to turn it on. If it's on (but flashing) press-and-hold it to make it light steady.

If you wish to control the **X** and **Y** outputs, then the **XY** button needs to be lit. If it's off, press it to turn it on. If it's on (but flashing) press-and-hold it to make it light steady.

*NOTE: In actuality, the joystick movements are always recorded regardless of whether or not the **ABCD** and **XY** buttons are on or off. But obviously, it makes sense to route the joystick to at least one destination while recording, so you can hear what's happening.*

2. Set the joystick to the position at which you want to begin your recording.

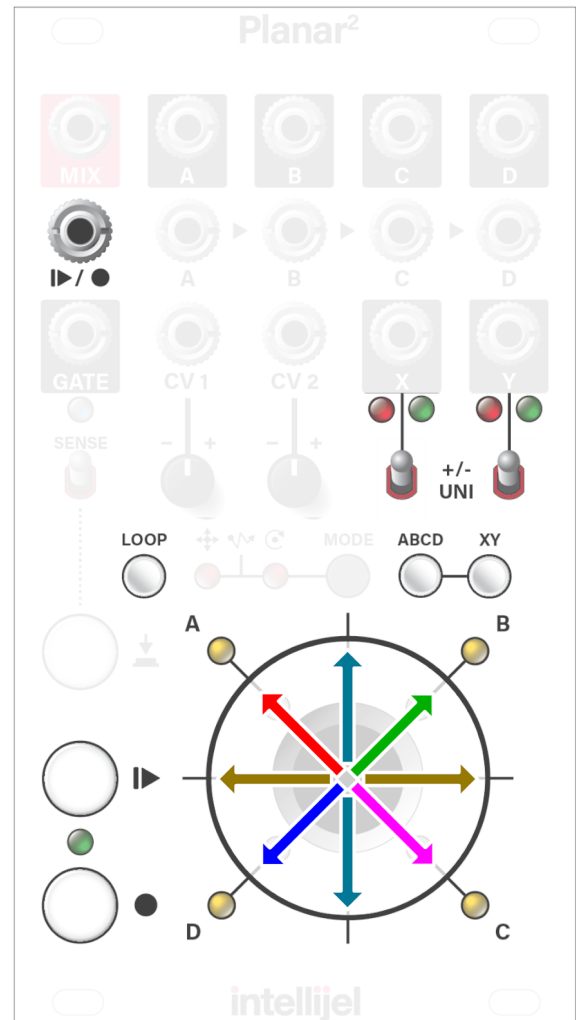

3. Press and release the **RECORD** button.

Planar² begins recording immediately after you press and release the **RECORD** button. The **RECORD** button glows red to indicate you're recording.

4. Wiggle the joystick around as desired, and use the Manual Gate button if you wish.
5. When you're finished, press and release the **RECORD** button.

Recording stops. The **RECORD** button light turns off and the **PLAY** button light begins to pulse (to indicate that a recording is present and ready to play back).

*NOTE: You can also stop the recording by pressing the **PLAY** button, which will both stop the recording and start playing it back immediately (either as a one-shot or as a loop, depending on whether the **LOOP** button is lit).*

TIP: If you plan to loop playback of your recording, you may wish to end the recording with the joystick in the same position as when you started the recording. That way the recording loops seamlessly.

To play back your recorded movements:

1. First, use the **LOOP** button to set whether your recording plays once and stops (like an envelope) or if it loops continuously (like an LFO).

Pressing the **LOOP** button toggles looped playback on and off. When the button is lit, playback loops. When the button is not lit, the recording plays once and stops. The loop button also has a third, flashing state, which in this example (since we're not using the trigger input) behaves the same as if the **LOOP** button was turned off.

See the **LOOP [P]** button description in the "[Front Panel](#)" section for a detailed breakdown of the various LOOP modes.

2. Next, use the **ABCD** and **XY** buttons to decide where to route playback.

In general, you'll probably route playback to the same destination you used when recording — but this option lets you re-route playback post-recording if you wish.

If the **ABCD** button is lit, then the recording controls the **A**, **B**, **C**, **D** and **MIX** outputs. If the **ABCD** button is unlit or flashing, then the recording is not sent to the **A**, **B**, **C**, **D** or **MIX** outputs.

If the **XY** button is lit, then the recording is set to the **X** and **Y** outputs. If the **XY** button is unlit or flashing, then the recording is not sent to the **X** or **Y** outputs.

See the **XY [B]** and **ABCD [C]** button descriptions in the "[Front Panel](#)" section for a detailed breakdown of the various output button modes.

3. Press and release the **PLAY** button to start playback.

Planar² begins playing back your recording immediately after you press and release the **PLAY** button. The **PLAY** button glows yellow to indicate that it's playing.

If the **LOOP** button is off (or flashing), the recording will play back once and stop.

If the **LOOP** button is on, you'll need to press and release the **PLAY** button to stop playback.

To punch-in/out of a recording:

NOTE: Use Punch-In recording when you want to overwrite a section of an existing recording. This is useful if you need to make small improvements to an existing recording, or if you wish to evolve it little-by-little over the course of a song.

1. Press the **PLAY** button to start playback of the existing recording.

If loop mode is off, you may want to press the **LOOP** button to turn on loop mode (lighting the button), since it's often easier to time your punch-in/out points by cycling the recording a few times first. If the **LOOP** button is flashing, press-and-hold it to light it steady.

2. When playback reaches the section you wish to record over, press and continue to hold-down the **RECORD** button.
3. Keep the **RECORD** button depressed while you wiggle the joystick or add new gates.

Your new joystick movements and gates will continue to overwrite the previous movements for as long as you hold the **RECORD** button.

4. When you're finished recording, release the **RECORD** button to punch-out.

The section you recorded has now replaced the original section.

To Erase a Recording:

Any time you create a new recording, Planar² automatically overwrites the existing one. However, should you wish to erase a recording entirely (essentially reverting Planar² to its power-on state), you can do so:

1. Make sure the current recording is not playing back.
2. Press and hold the **PLAY** button for more than one second.

The existing recording will be erased completely, and the **PLAY** button's back-lighting will go out completely (thus indicating that there is nothing to play back).

Syncing Record & Playback to an External Trigger

Being able to record your joystick movements without metrical constraint is nice for organically evolving patches, languid drones and ambient compositions. But what if you *want* metric rigidity? What if your patch or song is all about meter and rhythm? For this, there's the **TRIGGER** [▶/●] input on Planar².

When nothing is plugged into the **TRIGGER** input, Planar² places no metric constraint on the start and stop points of your recording. As described previously, Planar² simply begins recording the instant you press and release the **RECORD** button, and stops the instant you press and release it again. Ditto for playback.

When you use the **TRIGGER** [▶/●] input, Planar² no longer starts and stops the instant you press the **RECORD** or **PLAY** buttons. Instead, it starts or stops at the first trigger signal it sees *after* you press one of these buttons. This lets you time your recording or playback to external events. A divided clock is the most obvious source for the **TRIGGER** jack, since it would enable you to create and play recordings that conformed to some metric order. However, there's nothing that says you have to feed a steady clock into the **TRIGGER** jack. Perhaps you'd like to trigger recording or playback with the EOC signal from a Quadra Expander module? Or a logic output from a Plog? The choice is yours.

To record your joystick movements with the **TRIGGER** jack in use:

1. Connect a trigger source to the **TRIGGER** [▶/●] IN jack.

For this example, we'll send it a signal from a clock divider set to pulse once-per-measure.

2. Decide whether you want to monitor your joystick movements from the quadrant outputs (**ABCD** button) or from the X/Y outputs (**XY** button) or both.

If you wish to control the **A**, **B**, **C**, **D** and **MIX** outputs, then the **ABCD** button needs to be lit. If it's off, press it to turn it on. If it's on (but flashing) press-and-hold it to make it light steady.

If you wish to control the **X** and **Y** outputs, then the **XY** button needs to be lit. If it's off, press it to turn it on. If it's on (but flashing) press-and-hold it to make it light steady.

3. Set the joystick to the X/Y position at which you want to begin your recording.
4. Press and release the **RECORD** button.

The **RECORD** button begins to rapidly flash red, indicating that recording is armed but that Planar² is waiting for a trigger signal to begin recording.

As soon as Planar² sees a trigger at its **TRIGGER** [▶/●] input, it will begin to record and the **RECORD** button glows red to indicate this.

5. Wiggle the joystick around as desired, and use the Manual Gate button if you wish.
6. When you're finished, press and release the **RECORD** button.

The **RECORD** button begins to rapidly flash red, indicating that you're still recording, and are waiting for the next trigger signal for recording to stop. As soon as Planar² sees a trigger at its **TRIGGER [▶ / ●]** input, it will stop recording and the **RECORD** button will extinguish.

*NOTE: You can also stop the recording by pressing the **PLAY** button, which will both stop the recording at the next trigger pulse and start playing it back (either as a one-shot or as a loop, depending on whether the **LOOP** button is lit and whether it is flashing).*

TIP: If you plan to loop playback of your recording, you may wish to end the recording with the joystick in the same position as when you started the recording. That way the CV loops seamlessly.

*NOTE: Punch-in/out recording is unaffected by the trigger signal. Punch-in recording works exactly as described previously regardless of whether or not you're using the **TRIGGER** input.*

To play back your joystick movement with the **TRIGGER** jack in use:

1. First, use the **LOOP** button to set how your recording plays.

If the button is off, your recording plays once and stops (like an envelope). If the button is on, your recording loops continuously (like an LFO). If the button is flashing, the recording will play once, but re-play every time a new trigger is received. See the **LOOP [P]** button description in the "[Front Panel](#)" section for a detailed breakdown of the various LOOP modes and how to select them.

2. Next, use the **ABCD** and **XY** buttons to decide where to route playback.

In general, you'll probably route playback to the same destination you used when recording — but this option lets you re-route playback post-recording if you wish.

If you wish to control the **A**, **B**, **C**, **D** and **MIX** outputs, then the **ABCD** button needs to be lit. If it's off, press it to turn it on. If it's on (but flashing) press-and-hold it to make it light steady.

If you wish to control the **X** and **Y** outputs, then the **XY** button needs to be lit. If it's off, press it to turn it on. If it's on (but flashing) press-and-hold it to make it light steady.

*NOTE: See the **XY [B]** and **ABCD [C]** button descriptions in the "[Front Panel](#)" section for a detailed breakdown of the various output button modes.*

-
3. Press and release the **PLAY** button.

The **PLAY** button flashes rapidly indicating playback is waiting for a signal at its **TRIGGER** input jack. Once Planar² sees a trigger input, it plays the recording, lighting the **PLAY** button solid.

If the **LOOP** button is off, your recording plays once and stops (like an envelope), ignoring any subsequent triggers.

If the **LOOP** button is on, the recording will loop continuously (like an LFO), and you'll need to press and release the **PLAY** button to stop playback.

If the **LOOP** button is flashing, the recording will play once, but re-play every time a new trigger is received.

*NOTE: See the **LOOP [P]** button description in the "[Front Panel](#)" section for a detailed breakdown of the various **LOOP** modes and how to select them.*

Using CV Inputs

Use the **CV 1** and **CV 2** inputs to add external control over the **ABCD** and **XY** outputs. This enables you to perform some advanced automation techniques that would otherwise be difficult to achieve.

CV control over outputs **A-D** is possible if the **ABCD button** is in one of two states: LIT or UNLIT. If the **ABCD button** is FLASHING, that means only the joystick actively controls the outputs, and any incoming CV will not govern the **A-D** outputs.

Similarly, CV control over the **X** and **Y** outputs is possible if the **XY button** is in one of two states: LIT or UNLIT. If the **XY button** is FLASHING, that means CV is prevented from governing the **X** or **Y** outputs.

The **ABCD** and **XY** button states can be set independently, allowing you to assign CV input to influence the **A-D** outputs; **X** and **Y** outputs; both; or neither.

If an **XY** or **ABCD** button is unlit, press it to turn it on and light it. If an **XY** or **ABCD** button is lit, press it to turn it off and unlight it. Press and hold the **XY** or **ABCD** button to toggle between flashing and non-flashing states.

To learn more about the various **XY** and **ABCD** button functions, see the **XY [B]** and **ABCD [C]** button descriptions in the “[Front Panel](#)” section. For now, just realize that a steadily lit output button means **CV 1** and **CV 2** affect the levels appearing at the corresponding output. An unlit button also means **CV 1** and **CV 2** affect the levels appearing at the corresponding output, but since an unlit button mutes the effect of the joystick or recording, [Scan Automation](#) has no effect.

If an **XY** or **ABCD** button is lit, then the CV inputs are summed with the recorded values (if a recording is playing) or with the value dictated by the position of the joystick (if a recording is not currently playing). **X** and **Y** output values remain limited to the range set by each output’s POLARITY switch (-5V to +5V / 0V to +10V). **A**, **B**, **C** and **D** outputs are scaled to ensure unity gain.

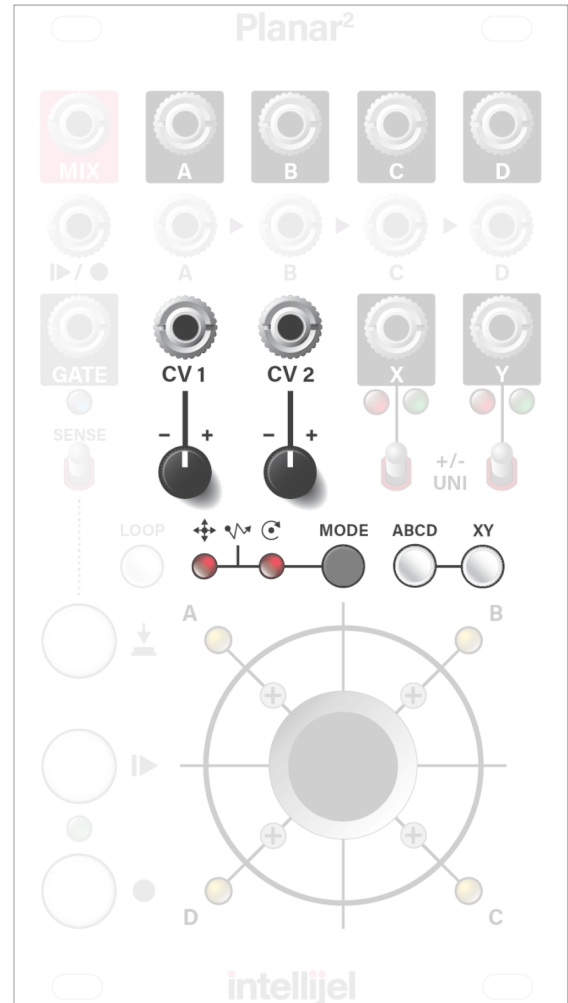

The way in which the two CV inputs affect the outputs is set by the front panel **MODE button & Indicator LEDs**. CV Input can operate in *Cartesian*, *Polar* or *Scan* modes, as described in the following sections.

Cartesian Automation



Press the **MODE** button repeatedly to cycle through the three CV automation modes. If the left LED is lit, **CV 1** and **CV 2** operate in *cartesian* mode, meaning Planar² assigns **CV 1** to *X-axis* control and **CV 2** to *Y-axis* control.

Because Cartesian mode uses the same X/Y grid pattern as the joystick, this makes it the easiest mode to visualize, and therefore the best mode for using CV to pinpoint precise locations on a grid.

The following diagram assumes the **ABCD** or **XY** buttons are off (meaning the corresponding outputs are controlled only by CV IN). If the **ABCD** or **XY** buttons are lit, then the CV IN values sum with the current joystick position (or its recorded value).

CARTESIAN COORDINATES EXAMPLE
(assumes both CV attenuverters are fully positive)

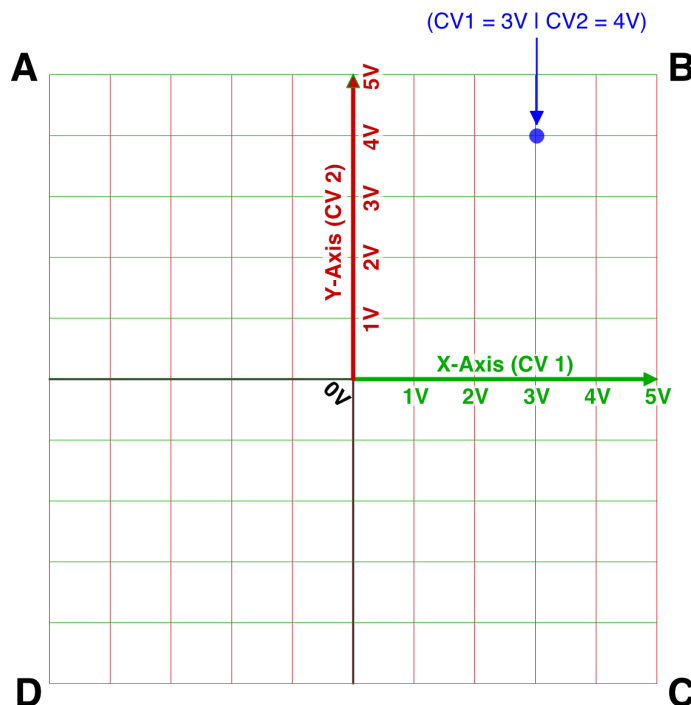

NOTE: Both **CV 1** and **CV 2** default to 0V if nothing is connected to their inputs.

Polar Automation



Press the **MODE** button repeatedly to cycle through the three CV automation modes. If the right LED is lit, **CV 1** and **CV 2** operate in *polar* mode, meaning Planar² assigns **CV 1** to *rotation* and **CV 2** to *radius*.

Polar mode lets you easily create spinning, circular patterns that would be difficult to achieve with Cartesian mode. For example, with 5V DC applied to **CV 2** and a single 0V-5V ramp wave at **CV 1**, you can create a circular pan that rotates through the four quadrants. By also sending a 5V-0V saw into **CV 2**, you create a spiralling, down-the-drain pattern.

The following diagram assumes the **ABCD** or **XY** buttons are off (meaning the corresponding outputs are controlled only by CV IN). If the **ABCD** or **XY** buttons are lit, then the CV IN values sum with the current joystick position (or its recorded value).

POLAR COORDINATES EXAMPLE
(assumes both CV attenuverters are fully positive)

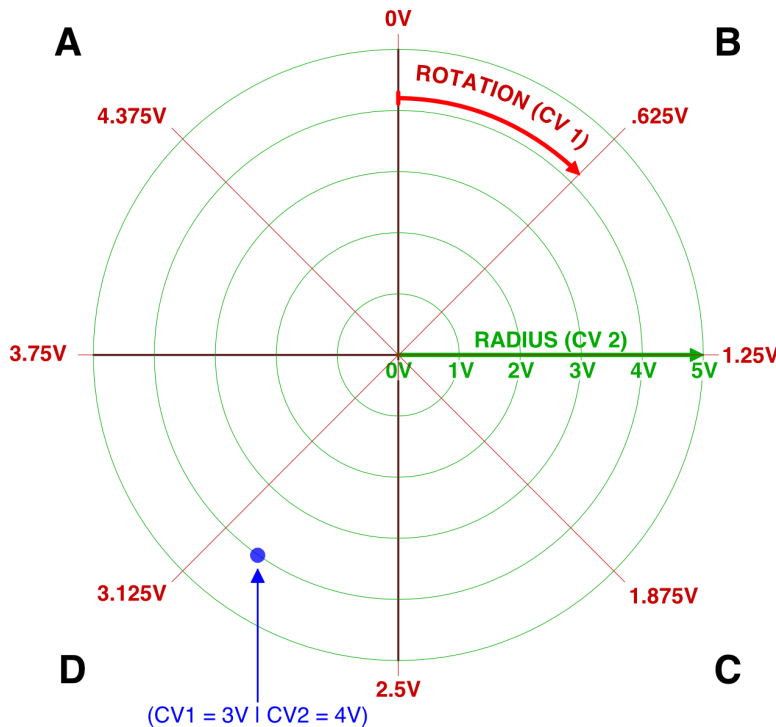

IMPORTANT: Both **CV 1** and **CV 2** default to 0V if nothing is connected to their inputs. So in order for the full effect on one control voltage to be seen, voltages should be applied to both CV inputs. For example, if you don't connect a voltage to **CV 2**, then **CV 1** will not have any visual or audible effect, since **CV 2** defaults to 0V, which is dead-center of the polar chart.

Scan Automation



Press the **MODE** button repeatedly to cycle through the three CV automation modes. If both LEDs are lit, **CV 1** and **CV 2** operate in *scan* mode. Scan mode requires that you first make a recording of your joystick movements (as described in [CV Gesture Recorder](#)).

Once you have a recording, use **CV 1** to locate the precise position of the virtual “play head” along the recording’s time axis, and use **CV 2** to set the linearity of that timeline. This enables you to scrub either forward or backward through any portion of a CV recording. Feed a slow envelope into CV1, and you can make a 10 second recording evolve for 30 minutes.

CV 1 scans through the current recording, with the absolute voltage level determining the position of the virtual “play head.” **CV 1** ignores polarity in scan mode, meaning 0V always conforms to the beginning of the recording and $\pm 5V$ to the end.

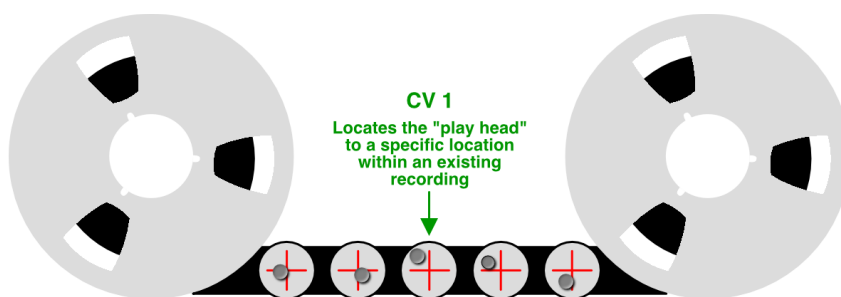

CV 2 controls the linearity of the timeline.

With 0V applied to **CV 2** (or with nothing connected to its input), then the voltage applied to **CV 1** maps linearly to the recorded timeline. In other words, if **CV 1** = 2.5V (midway through the input’s 0-5V range), then the virtual play head will be located precisely in the middle of the recorded stream of CV voltages.

With positive voltages applied to **CV 2**, access to the recorded timeline becomes logarithmic. In other words, if **CV 1** = 2.5V (midway through the input’s 0-5V range), then the virtual play head will be located at a position much closer to the beginning of the recording than the end. The higher the voltage, the greater the nonlinearity.

With negative voltages applied to **CV 2**, access to the recorded timeline becomes exponential. In other words, if **CV 1** = 2.5V (midway through the input’s 0-5V range), then the virtual play head will be located at a position much closer to the end of the recording than the beginning. The more negative the voltage, the greater the nonlinearity.

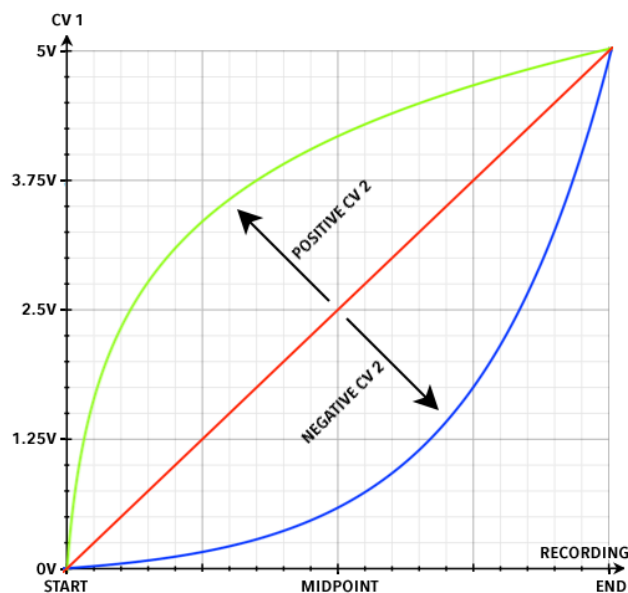

CV Automation Example

This example discusses one example of using CV inputs to affect the **A**, **B**, **C** and **D** outputs, and uses the **ABCD button** accordingly. The procedure is similar for controlling **X** and **Y** outputs if the **XY button** is used.

1. If the **ABCD button** is lit (or flashing), press it to turn it off. When the **ABCD button** is not lit, only the CV inputs affect the **A-D** output levels — neither the joystick nor any recorded movements have any effect.

*NOTE: You can also use the CV inputs in conjunction with the joystick or its recorded movements. This occurs when the **ABCD button** is lit (but not flashing). You can toggle between flashing and lit states by pressing and holding the **ABCD button**. When using CV inputs in conjunction with the joystick/recording, their values are summed together.*

For sake of simplicity, the remainder of this example looks at automating panning & crossfading using only the CV inputs.

2. Connect your inputs and outputs as described in one of the previous tutorials. For this example, set up Planar² as a standard Quad Crossfader as outlined earlier in the [“Manual Quad Crossfader”](#) section.

Specifically, connect four different audio sources to inputs **A**, **B**, **C** and **D**, then route the MIX output into your sound system.

3. Plug a control signal into **CV 1** and another into **CV 2**. You can use gates, envelopes, LFOs, random voltages or even audio to modulate each of the two CV inputs.
4. Rotate the **attenuverters** for **CV 1** and **CV 2** to set both the direction and extent to which the external voltages control the crossfade.
5. Press the **MODE** button repeatedly to cycle through (and select) one of the three available coordinate modes.

These modes map the **CV 1** and **CV 2** inputs to one of three different coordinate systems (Cartesian; Polar; Scan) as discussed earlier. The coordinate system you choose dramatically alters how incoming CV controls the crossfades.

6. Send control voltages into **CV 1** and **CV 2**, and listen to the crossfades that result. You can watch the **A**, **B**, **C** and **D** Quadrant LFOs to get a visual representation of the crossfading.

Calibration

Planar² is calibrated at the factory prior to shipment. Calibration involves making sure all the default values behave as designed and expected. In the unlikely event you need to recalibrate your Planar², perform the simple automatic calibration procedure, listed below. Should the auto calibration fail to restore your Planar² to factory conditions, you may perform a manual calibration.

Automatic Calibration

1. Turn off the power to the Planar².
2. **IMPORTANT:** Make sure nothing is plugged into either the **CV 1** or **CV 2** jacks.
3. Press and hold the **MODE** button as you power up the Planar².
Planar² runs through a very quick (2-3 second) self-calibration procedure.
4. Long-press (>1 sec) the **LOOP** button to save the calibration and exit Calibration Mode.

Manual Calibration

Manual calibration requires a voltmeter with .001 volt accuracy.

1. Turn off the power to the Planar².
2. **IMPORTANT:** Make sure nothing is plugged into either the **CV 1** or **CV 2** jacks.
3. Press and hold the **MODE** button as you power up the Planar².
Planar² runs through a very quick (2-3 second) self-calibration procedure as it enters Calibration Mode.
4. Make sure Planar² is in **Cartesian** mode.
If Planar² is not currently in Cartesian mode, press the **MODE** button until the Cartesian mode LED is lit.

Unipolar Calibration:

5. Set both the **X Polarity** and **Y Polarity** switches to **UNI**.
6. Push the **ABCD** button to illuminate it.
Calibration of the **X** output requires that the **ABCD** button be lit.
7. Connect the **X** output to a voltage meter. It should be fairly close to 0.000V.

8. If the voltage reads *below* 0V, repeatedly press the **GATE** button to increase it until you reach 0.000V (as close as possible). If the voltage reads *above* 0V, repeatedly press the **REC** button to decrease it until you reach 0.000V (as close as possible).

NOTE: Voltage changes in very fine increments to facilitate precise calibration. If you wish to increase/decrease voltage more quickly, press the **PLAY** button to illuminate it and change voltage is coarser increments. Pressing the **PLAY** button toggles between Coarse and Fine increments for the **GATE** and **REC** buttons.

9. Push the **XY** button to illuminate it.

Calibration of the **Y** output requires that the **XY** button be lit.

10. Connect the **Y** output to a voltage meter. It should be fairly close to 0.000V.
11. Repeat the procedure outlined in Step 8, above, to calibrate the **Y** output.

Bipolar Calibration:

12. Set both the **X Polarity** and **Y Polarity** switches to **+/-**.
13. Repeat Steps 6-11 to calibrate the X and Y Bipolar outputs.

Save Calibration:

14. Long-press (>1 sec) the **LOOP** button to save the calibration and exit Calibration Mode.

Calibration Testing

Testing X Output:

1. Patch the **X** output into your voltmeter.
2. If the **XY** button is illuminated, press it to turn it OFF.
3. Set the **X Polarity** switch to **+/-** (bipolar) mode.
4. Verify that the voltage is 0.0xx volts.
5. Press the **XY** button to illuminate it, turning on the joystick.
6. Move the joystick along the X-axis and verify that the voltage ranges from -4.9xx volts to +4.9xx volts.
7. Set the X Polarity switch to **UNI** (unipolar mode).
8. Move the joystick along the X-axis and verify that the voltage ranges from 0.0xx volts to +9.9xx volts.

Testing Y Output:

1. Repeat steps 1-8 (under "Testing X Output") using the **Y** output jack and **Y Polarity** switches.

Firmware

1.02 (2019-07-27)

- Fix shortened loop times.

1.01 (2019-02-28)

- Fix: Mixer bleed
- Fix: Looper glitch

1.0 (2018-07-27)

- Initial release

Technical Specifications

Width	14 hp
Maximum Depth	40 mm
Current Draw	85 mA @ +12V 32 mA @ -12V