

User Guide

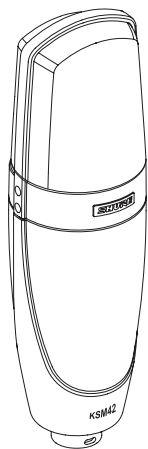

KSM42



SHURE INCORPORATED



KSM42

CARDIOID CONDENSER MICROPHONE

Thank you for selecting the KSM42.

Over 85 years of audio experience has contributed to making this one of the finest microphones available.





General Description

This premium side-address, cardioid condenser microphone features a large dual-diaphragm optimized for world-class vocal recording and performance applications. With a tailored frequency response and extensive internal and external pop filtering, the single-pattern, dual-diaphragm design of the KSM42 exhibits an exceptionally smooth frequency response and ultra-wide dynamic range. The KSM42 is the premier choice for capturing sophisticated and intimate vocal performances.

Features

- Highly consistent cardioid polar pattern creates a broad “sweet spot” and natural off-axis response
- Dual-diaphragm design with an active front, ultra thin (2.5 micron) 24-karat gold, low mass, 1-inch Mylar® diaphragm
- Passive back diaphragm delivers exceptional control of low frequency proximity effect
- Tailored low-frequency roll-off minimizes low frequency room noise
- Integrated three-stage mesh grille guards against wind and breath noise—magnetic pop filter attachment for additional pop protection
- Open cage ShureLock® rubber suspension shock mount with low-profile magnetic pop filter produces a natural space between performer and microphone
- Extremely low self noise for critical studio vocal recording
- Advanced preamplifier technology exhibits extremely low self-noise with superior dynamic range, transient response and ultra-low distortion for transparent recording
- Premium electronic components and gold-plated internal and external connectors
- Durable zinc die-cast housing and hardened low carbon steel grille
- Internal shock mount to reduce unwanted handling and stand noise

Performance Characteristics

- Consistent frequency response, irrespective of distance
- High output level
- Extensive pop filtering protection system (internal and external)
- High input SPL capability
- Ultra-low distortion
- Uniform polar response
- Superior common mode rejection and suppression of radio frequency interference

Applications

The KSM42 is designed primarily for:

- Solo and backing vocals
- Voice-overs
- Speech

Secondary uses might include:

- Ensembles—choral or orchestral room ambiance pick-up
- Acoustic instruments—piano, guitar, and stringed instruments
- Wind instruments—brass and woodwinds

OPERATION

Power Requirements

This microphone requires phantom power and performs best with a 48 Vdc supply (IEC-268-15/DIN 45 596). However, it will operate with slightly decreased headroom and sensitivity with supplies as low as 11 Vdc. Most modern mixers provide phantom power. You must use a **balanced** microphone cable: XLR-to-XLR or XLR-to-TRS.

Suspension Mount

Use the supplied ShureLock® rubber suspension mount to secure the microphone to a floor or boom stand.

Important: Thread the knurled locking ring securely to the base of the microphone. Do not overtighten.



Positioning

Position the front of the microphone, with **SHURE**, towards the desired sound source. Position the rear of the microphone, with the vintage circle S logo, towards any unwanted sound sources.



Pop Filter

An integrated three-stage mesh grille guards against wind and breath noise. Use the included pop filter accessory for additional protection against breath and “plosive” noises. The pop filter magnetically attaches to the front of the shockmount ring.



Reduction of Proximity Effect

To counter proximity effect, the KSM42 uses two diaphragms, one active and one passive, to create an acoustic phase shift at the rear of the microphone. This produces a broad “sweet spot” of uniform low-frequency response, allowing the performer to move closer or further from the microphone with minimal changes in sound quality.

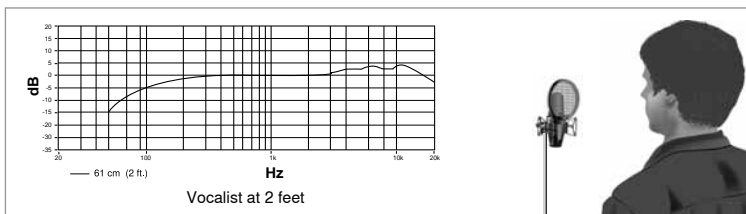

SPECIFICATIONS

Transducer Type	Dual-Diaphragm, Front-Active, Externally Biased Condenser
Frequency Response	60 to 20,000Hz
Polar Pattern	Cardioid
Output Impedance	147 Ω
Sensitivity (at 1 kHz, open circuit voltage)	-37 dBV/Pa (14.1 mV) 1 Pascal=94 dB SPL
Maximum SPL (1 kHz at 1% THD)	1000 Ω load: 139 dB 2500 Ω load: 139 dB THD of microphone preamplifier when applied input signal is equivalent to cartridge output at specified SPL
Signal-to-Noise Ratio (referenced at 94 dB SPL at 1 kHz)	86 dB S/N ratio is difference between 94 dB SPL and equivalent SPL of self noise, A-weighted
Dynamic Range (at 1 kHz)	1000 Ω load: 131 dB 2500 Ω load: 131 dB
Common Mode Rejection (10 Hz to 100 kHz)	> 60 dB
Clipping Level (20Hz-20 kHz at 1% THD)	1000 Ω load: 6.5 dBV 2500 Ω load: 8 dBV
Self Noise (typical, equivalent SPL, A-weighted)	8.5 dB
Polarity	Positive pressure on diaphragm produces positive voltage on pin 2 with respect to pin 3
Weight	Net: 494 g with shock mount and pop filter: 820 g
Connector	Three-pin professional audio (XLR), male
Power Requirements	11 to 52 Vdc phantom, 6 mA

ACCESSORIES AND PARTS

Furnished Accessories

Magnetic Pop Filter	A42PF
ShureLock® Rubber Suspension Shock Mount	A42SM
Aluminum Carrying Case	A42SC
Protective Velveteen Pouch	A42VB
Suspension Mount O-rings (4)	A42OR

Optional Accessories

Windscreen	A32WS
Padded, Zippered Carrying Bag	A32ZB
Swivel Stand Mount	A32M

Replacement Parts

Suspension Mount O-rings (4)	A42OR
------------------------------	-------

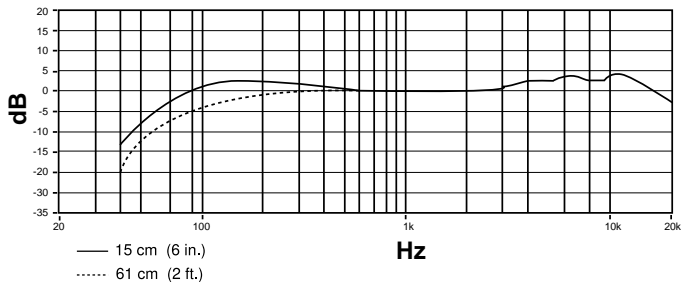

TYPICAL FREQUENCY RESPONSE
 COURBE DE REONSE TYPIQUE - TYPISCHES FREQUENZVERHALTEN - RESPUESTA DE FRECUENCIA TIPICA
 TIPICA RISPOSTA IN FREQUENZA - 周波数特性

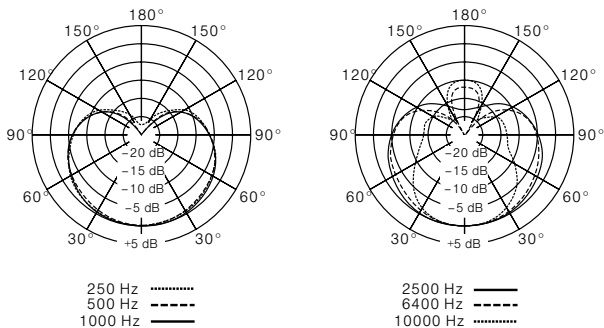

TYPICAL POLAR PATTERNS
 COURBE DE DIRECTIVITE TYPIQUES - TYPISCHE POLARCHARAKTERISTIK - PATRONES DE CAPTACION POLAR
 TIPICOS - TIPICI DIAGRAMMI POLARI - 指向特性

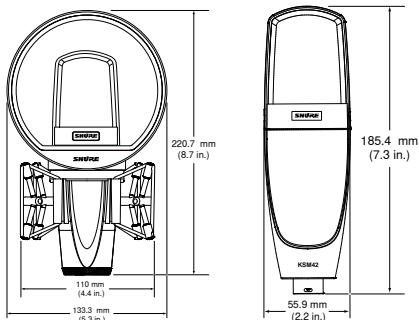

OVERALL DIMENSIONS - DIMENSIONS
 HORS TOUT
 GESAMTABMESSUNGEN - DIMENSIONES
 TOTALES - DIMENSIONI TOTALI - 寸法

Trademark Notices: The circular S logo, the stylized Shure logo, the word "Shure," and "ShureLock" are registered trademarks of Shure Incorporated in the United States. "Popper Stopper" is a trademark of Shure Incorporated in the United States. "Mylar" is a registered trademark of E.I. DuPont de Nemours and Company in the United States. These marks may be registered in other jurisdictions.

Patent Notice: Pat. D447,131

SHURE®