

RF-15.64

Reference series



FEATURES

- » 2-way vented loudspeaker system
- » 15" cone speaker
- » 1.5" compression driver with constant directivity horn
- » 600 W power handling

SPECIFICATIONS

RMS (Average) Power Handling^R:	Passive: 600 W LF: 600 W HF: 100 W
Program Power Handling^P:	Passive: 1200 W LF: 1200 W HF: 200 W
Peak Power Handling^K:	Passive: 2400 W LF: 2400 W HF: 400 W
On-axis Frequency Range:	45 Hz - 20 kHz
Nominal Impedance:	Passive: 8 Ω; LF: 8 Ω; HF: 8 Ω
Minimum Impedance:	LF: 7.6 (50 Hz); HF: 6.9 Ω (20 kHz)
On-axis Sensitivity 1W / 1 m:	LF: 98 dB SPL HF: 99 dB SPL
Rated Peak SPL at Full Power:	LF: 131 dB HF: 125 dB
Nominal -6 dB Beamwidths:	60° Horizontal x 40° Vertical
Enclosure Material:	Wisa® Birch Plywood
Finish:	Black Paint
Transducers/Replacement Parts:	LF: 15 H/GM 15G HF: M-10N/GM M-10
Connector:	2 paralleled NL4 Speakon, wired to ±1
Dimensions (H x W x D):	73 x 41.6 x 41.5 cm 28.7 x 16.4 x 16.3 in
Weight:	31 kg (62.2 lb)
Accessories (optional):	ANL-2; AXU-RF15; AX-Truss; AXA-2RF15; AXA-3RF15; TRD-2; TRD-4

INTRODUCTION

The D.A.S. RF-15.64 is a 2-way vented loudspeaker system designed for applications covering speech reinforcement, program reproduction and live music productions.

DESCRIPTION

The low end utilizes a high efficiency 15" low frequency speaker with 4" voice coil.

The high end makes use of a 1.5" exit compression driver with 3" titanium diaphragm, coupled to a rotatable 60° x 40° horn.

The enclosure is manufactured from Wisa® Birch plywood and is finished with a durable black paint. The trapezoidal enclosure has 10 degree side angles for easier arraying.

The unit has a robust grille design internally lined with acoustically transparent filter cloth to protect the loudspeaker components. The covering is resistant to wear and tear, provides protection from dust and dirt.

12 integrated rigging points that accept 10M forged steel eyebolts make suspension in either the horizontal or vertical positions safe and simple. The D.A.S. RF-15.64 is stand and pole mountable, and 2 or 3 units can be arrayed using AXA accessories.

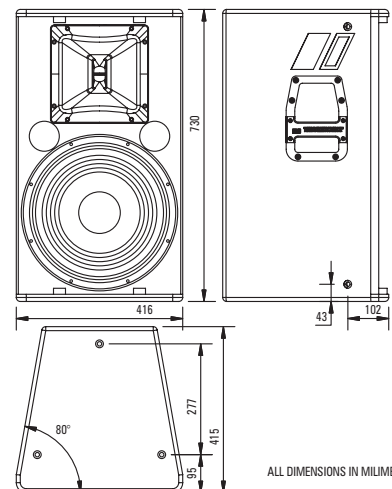

ALL DIMENSIONS IN MILLIMETERS

^R Based on a 2 hour test using a 6 dB crest factor pink noise signal bandlimited according to IEC 268-1 (1985). All power ratings are referred to the nominal impedance.

^P Conventionally 3 dB higher than the RMS measure, although this already utilizes a program signal.

^K Corresponds to the signal crests for the test described in^P.

FREQUENCY RESPONSE

Figure 1 shows the frequency response at 1 m of a unit radiating to a half space anechoic environment and driven by a 1 W (2.83 V) swept sine signal, and impedance curve.

Low frequency (grey).
High frequency (dotted).

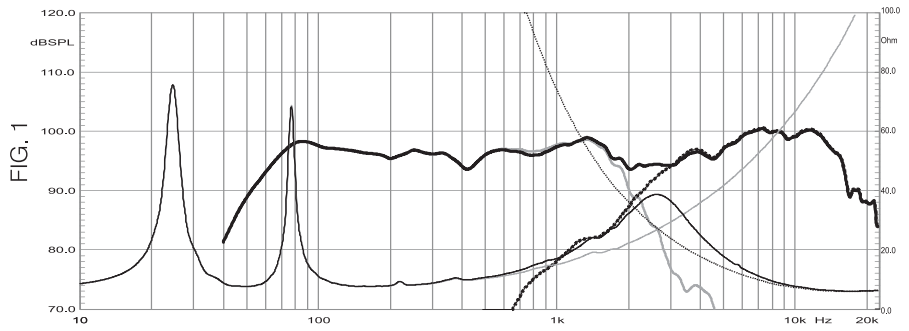

DISTORTION

Figure 2 shows the Second Harmonic Distortion (grey) and Third Harmonic Distortion (dotted) curves for a unit driven at 10% of its nominal power handling rating.

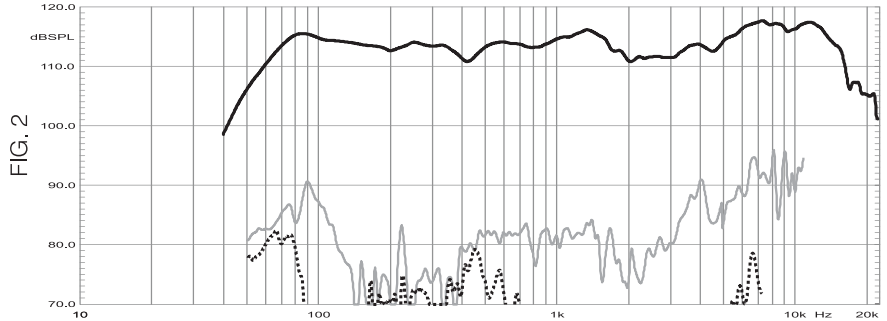

DIRECTIVITY

Figure 3 shows normalized horizontal isobar plot.

Figure 4 shows normalized vertical isobar plot.

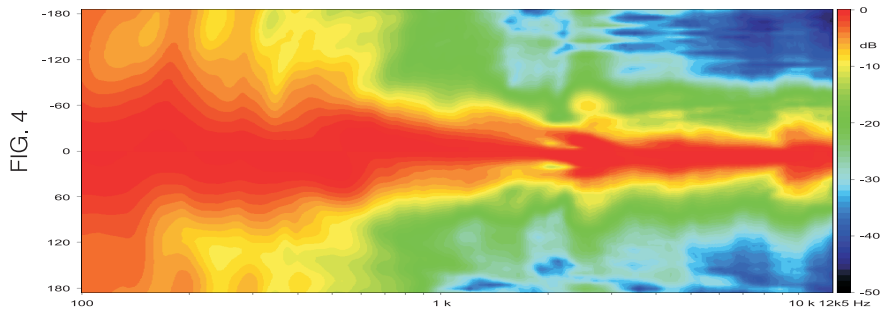
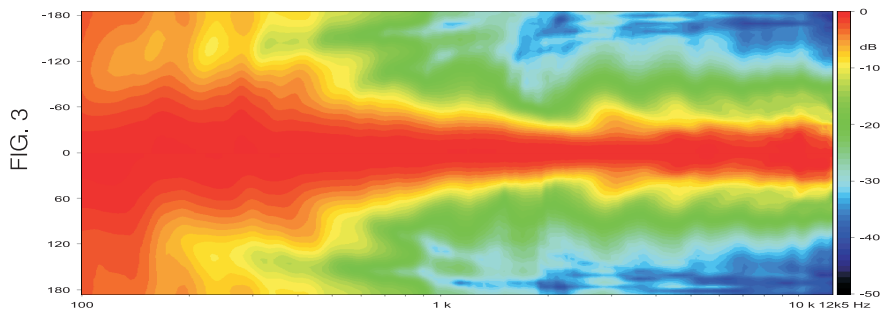

POLAR RESPONSE

Figure 5 shows the 1/3 octave band horizontal (left) and vertical (right) polars for the indicated frequencies. Full scale is 30 dB, 6 dB per division.

All figures of Distorsion, Directivity and Polar Response are measured in passive mode.

NOTES. 1.Frequency response: referred to 1 m; low end obtained through the use of near field techniques; one-third octave smoothed for correlation with human hearing.
5.Polars were acquired by placing the unit on a computer controlled turntable inside our anechoic chamber. Measurement distance was 4 m.

Product improvement through research and development is a continuous process at D.A.S. Audio. All specifications subject to change without notice.

