

ATM350a Cardioid Condenser
Instrument Microphone Systems

COVERED

Whatever your instrument, Audio-Technica has an ATM350a microphone system to ensure it sounds great. Not only does this cardioid condenser come with an array of mounts – many with a re-engineered, robust gooseneck built to stay where you set it – but it also provides clear, well-balanced response (even at high SPLs), reduces side and rear pickup for excellent isolation of the instrument, and includes a switchable 80 Hz high-pass filter on its in-line power module to control unwanted ambient noise. So no matter what, where or how you play, the ATM350a has you covered.

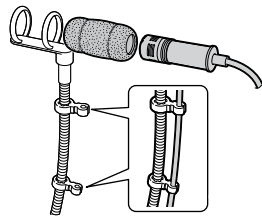

Strong, flexible gooseneck (5" or 9") positions mic where you want it – and keeps it there.

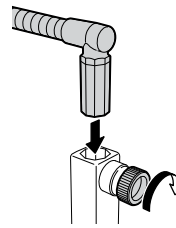

Gooseneck's octagonal base locks securely into mounts.

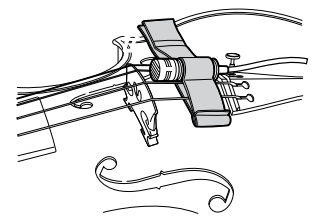

Versatile Violin Mount (hook-and-loop fastener) is included with each system.



ATM350U **Universal Mounting System** (short)

With a 5" gooseneck and universal clip-on mount, the ATM350U is ideal for brass and sax players, yet is versatile enough to fit nearly any application. The mount features strong, rubber-lined clamping jaws and a locking screw to securely fasten the mount to the bell of your instrument or other surface. The socket screw locks the gooseneck to the mount, giving you the flexibility to position the mic exactly where you want it and the confidence to play freely, knowing that the mic will stay in place, no matter how much you move about.



Includes: ATM350a Microphone, AT8543 Power Module, AT8491U Universal Clip-on Mount, AT8490 5" Gooseneck, AT8468 Violin Mount (hook-and-loop fastener), Protective Carrying Case

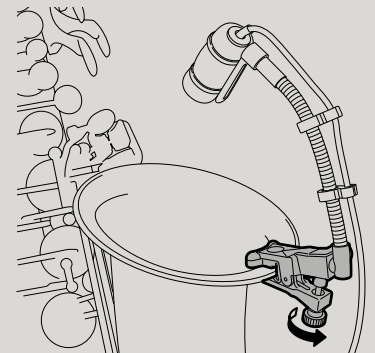

Locking screw secures clip-on mount to instrument bells or other surfaces.

ATM350UcW **Wireless Universal Mounting System**

Includes: ATM350acW wireless microphone terminated with locking 4-pin connector for use with Audio-Technica UniPak® body-pack wireless transmitters, AT8491U Universal Clip-on Mount, AT8490 5" Gooseneck, AT8468 Violin Mount (hook-and-loop fastener), Protective Carrying Case



ATM350UL **Universal Mounting System** (long)

The long universal mounting system includes the same adjustable clip-on mount as the shorter version, but with a 9" gooseneck. This is perfect for musicians who like to position the mic farther away from the instrument's bell or for those playing big-belled instruments like the tuba.



Includes: ATM350a Microphone, AT8543 Power Module, AT8491U Universal Clip-on Mount, AT8490L 9" Gooseneck, AT8468 Violin Mount (hook-and-loop fastener), Protective Carrying Case



ATM350PL Piano Mounting System

This system's unique magnetic mount attaches to the piano's cast iron frame or other metal part, allowing you to easily position the mic exactly where you want it. Whether set up vertically or horizontally, the mount stays where it is placed, but can also be repositioned with ease. Like the mounts in other ATM350a systems, the piano mount includes a screw to lock its 9" gooseneck into the mounting socket, and its base is lined with felt to prevent damage to the instrument.

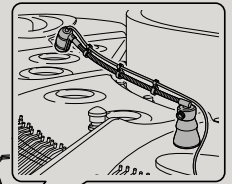

Includes:

ATM350a Microphone, AT8543 Power Module, AT8491P Magnetic Piano Mount, AT8490L 9" Gooseneck, AT8468 Violin Mount (hook-and-loop fastener), Protective Carrying Case



ATM350D Drum Mounting System

The Drum Mounting System is designed to stand up to powerful drumming. The spring-loaded mount clamps onto a tension rod (without hindering your ability to adjust the tension) and provides excellent shock resistance for the mic. The sturdiness of the 5" gooseneck ensures that the mic will stay where you set it and won't bounce around, no matter how hard you play.



Includes:

ATM350a Microphone, AT8543 Power Module, AT8491D Drum Mount, AT8490 5" Gooseneck, AT8468 Violin Mount (hook-and-loop fastener), Protective Carrying Case

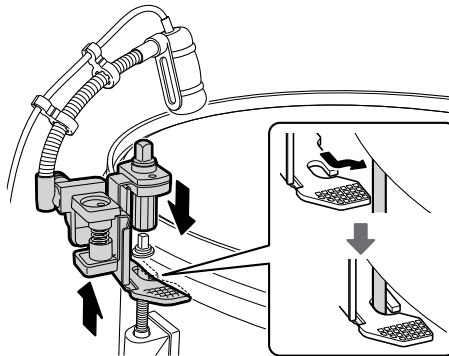

Drum mount's spring-loaded mechanism fastens it tightly to the drum rim/tension rod.

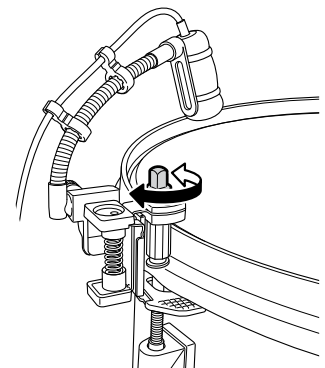

Mount design retains tuning key access to the tension rod.



ATM350W Woodwind Mounting System

The adjustable hook-and-loop strap on the woodwind mount allows it to be easily attached just above the bell of the instrument. Specially designed contact points on the base of the mount minimize damping of the instrument's resonance, while the strap's rubber pad (opposite the mount) ensures a secure fit. The sturdy 5" gooseneck lets you adjust the proximity of the mic to the bell, as desired.



Includes:

ATM350a Microphone, AT8543 Power Module, AT8491W Woodwind Mount, AT8490 5" Gooseneck, AT8468 Violin Mount (hook-and-loop fastener), Protective Carrying Case

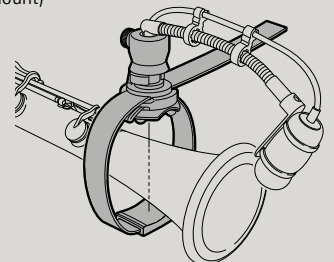

ATM350a Cardioid Condenser Instrument Microphone Systems

UniMount® Components

AT8490
5" Gooseneck



AT8490L
9" Gooseneck



AT8491D
Drum Mount



AT8491P
Magnetic
Piano Mount



AT8491U
Universal
Clip-on Mount



AT8491W
Woodwind Mount



UniMount® Component Systems

AT8492D
Drum Mounting System (5" Gooseneck)

Includes:
AT8491D Drum Mount and AT8490 5" Gooseneck.



AT8492PL
Magnetic Piano Mounting System (9" Gooseneck)

Includes:
AT8491P Magnetic Piano Mount and AT8490L 9" Gooseneck



AT8492U
Universal Clip-on Mounting System (5" Gooseneck)

Includes:
AT8491U Universal Clip-on Mount and AT8490 5" Gooseneck



AT8492UL
Universal Clip-on Mounting System (9" Gooseneck)

Includes:
AT8491U Universal Clip-on Mount and AT8490L 9" Gooseneck



AT8492W
Woodwind Mounting System (5" Gooseneck)

Includes:
AT8491W Woodwind Mount and AT8490 5" Gooseneck



ATM350a Specifications

Element Fixed-charge back plate, permanently polarized condenser

Polar pattern Cardioid **Frequency response** 40–20,000 Hz

Low Frequency Roll-off 80 Hz, 12 dB/octave **Impedance** 200 ohms

Open circuit sensitivity –49 dB (3.5 mV) re 1V at 1 Pa*

Maximum input sound level 159 dB SPL, 1 kHz at 1% T.H.D.

Dynamic range (typical) 130 dB, 1 kHz at Max SPL

Signal-to-noise ratio¹ 65 dB, 1 kHz at 1 Pa*

Phantom power 11–52V DC, 3.5 mA typical

Switch Flat, roll-off **Weight (mic)** 14.5 g (0.5 oz)

Dimensions (mic) 37.8 mm (1.49") long, 12.2 mm (0.48") maximum body diameter

Output Connector Power module: Integral 3-pin XLRM-type

Polar Pattern

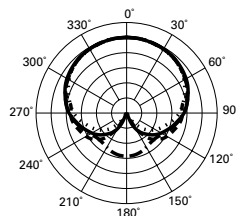

SCALE IS 5 DECIBELS PER DIVISION

LEGEND
200 Hz ———
1 kHz ———
5 kHz ·····
8 kHz - - - -

Frequency Response: 40–20,000 Hz

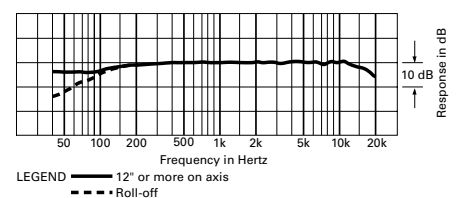

LEGEND ——— 12" or more on axis
- - - - Roll-off



Audio-Technica U.S., Inc. 1221 Commerce Drive, Stow, Ohio 44224 (330) 686-2600 E-mail: pro@atus.com
Form No. 0305-0861-00 Printed in U.S.A. ©2016 Audio-Technica U.S., Inc. audio-technica.com

In the interest of standards development, A.T.U.S. offers full details on its test methods to other industry professionals on request.

¹ Typical, A-weighted, using Audio Precision System One.

* 1 Pascal = 10 dynes/cm² = 10 microbars = 94 dB SPL

Specifications are subject to change without notice.