

1. Introduction

Module **A-162 (Dual Trigger Delay)** contains **two separate delay circuits** for trigger signals.

This module makes it possible to delay the onset of a trigger pulse, and also change its length (see Fig. 1 on page 3).

On each of the trigger delays, two controls can alter the **onset time** and **duration** of triggers, from 0 up to round about ten seconds. A control LED indicates the onset and duration of the new trigger.

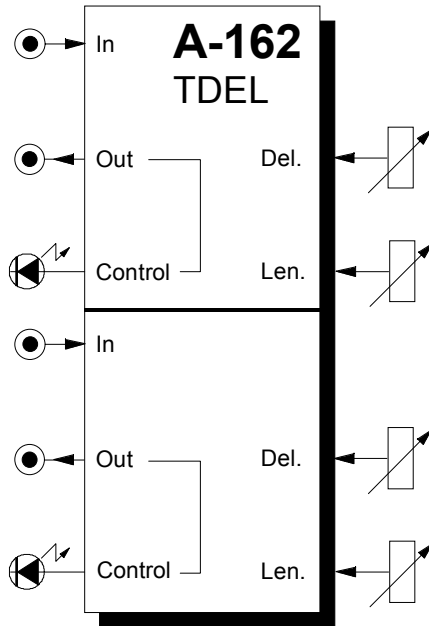

2. Overview

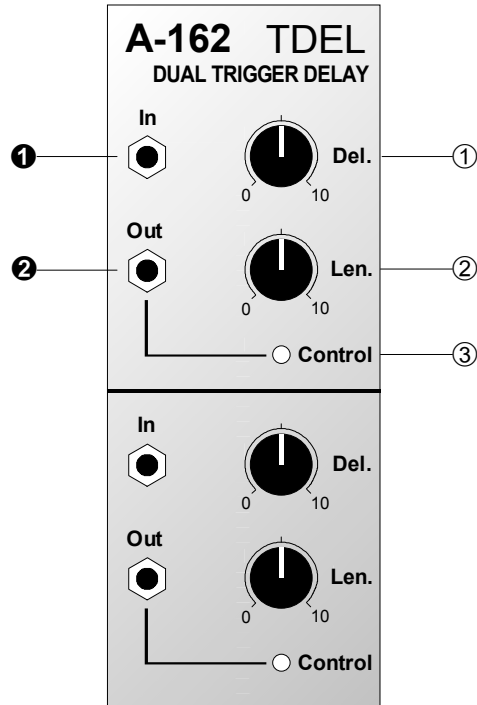

Controls and indicators:

For each trigger delay:

- ① **Del. :** Delay control
- ② **Len. :** Trigger length control
- ③ **LED :** Trigger pulse output indicator

In / Outputs:

- ① **In :** Trigger signal input
- ② **Out :** Output

3. Controls and indicators

① Del.

This control sets the **trigger delay time** t_D (see Fig. 1) in a range from zero to ten seconds.

② Len.

This control ② sets the length t_L of the trigger pulse (see Fig. 1) in a range from zero to ten seconds.

③ LED

LED ③ lights when a trigger pulse is being output.

4. In / Outputs

① In

Socket ① is the A-162's **input**. This is where you patch the trigger pulse in whose rising edge will start the process.

② Out

The delayed trigger signal is output here.

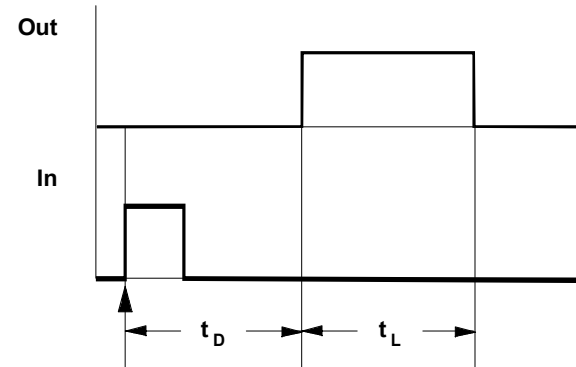

Fig. 1: How the A-162 delays and lengthens a pulse

5. User examples

Modulation delay

The A-162 is particularly useful for **delaying the onset of modulation**, for instance of a VCF, VCO, VCA, etc., by causing the gate to open later. It can also create pseudo echo effects.

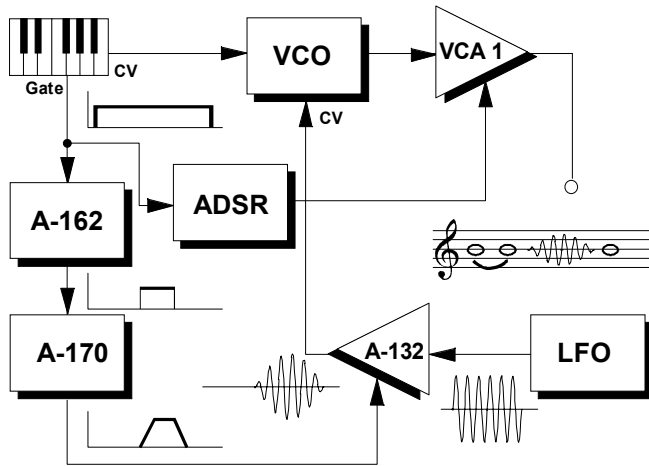

Fig. 2: Delayed vibrato

In the example in Fig. 2, the onset of vibrato (sub-audio frequency modulation of a VCO) is delayed by using the A-162 to delay the gate which will open the

VCA. By patching in an AR envelope (in this case an A-170, but an A-140 could also do the job) the intensity of the vibrato can increase and decrease gradually.

Stereo "Echo"

The patch in Fig. 3 produces a sort of stereo echo. When a key is pressed, the sound first comes out of the **Out_L** left VCA output, and then, after a delay set by the A-162, the 'echo' comes out of the right VCA output, **Out_R**.

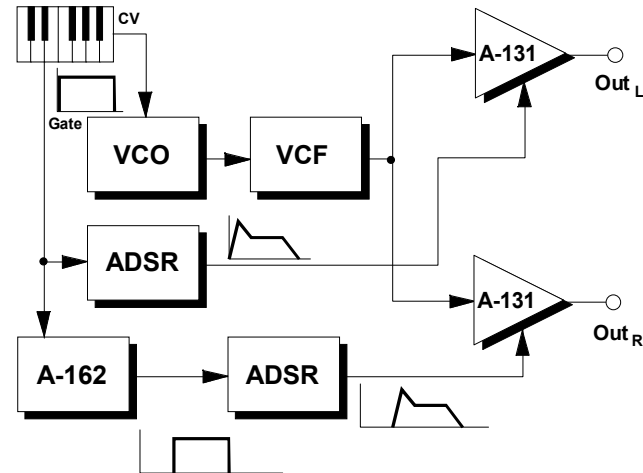

Fig. 3: Stereo "echo"

6. Patch-Sheet

The following diagrams of the module can help you recall your own **Patches**. They're designed so that a complete 19" rack of modules will fit onto an A4 sheet of paper.

Photocopy this page, and cut out the pictures of this and your other modules. You can then stick them onto another piece of paper, and create a diagram of your own system.

Make multiple copies of your composite diagram, and use them for remembering good patches and set-ups.



- Draw in patchleads with colored pens.
- Draw or write control settings in the little white circles.

