

ECHOZ



ZVERB



Z5000



A user manual for ECHOZ ZVERB Z5000 effect modules

This user manual covers the use of the **ECHOZ**, **ZVERB** and the **Z5000** Multi Effects modules. Due to similarities in method of operation this user manual covers all 3 modules with sections describing the programs on each afterward.

ECHOZ - Is an FX module fully dedicated to time delay effects from emulation of tape echoes to early digital delays to complex multi-fx units. 24 different programs cover a wide range of options and internal signal path structures.

ZVERB - Has 24 different types of effects available ranging from typical reverbs to more complex effects that combine delay and pitch shifting with reverb. The effects are grouped by decades based on either the era an algorithm or device was introduced or the time when the effect was most popular.

Z5000 - The Z5000 is a Multi Effects module, it provides 24 effects that include reverbs, delays, modulation, pitch and harmonizers. The effects in the Z5000 were carefully selected to provide both commonly used delay and reverbs and also some unusual sounding and experimental effects.

Hardware Features:

- 8hp
- 3 illuminated buttons for bank selections
- 8 programs per bank, total 3 banks
- 3 CV inputs for all 3 DSP parameters
- Analog clocking of DSP with CV
- Black version: +12V@130mA -12V@20mA
- White version: +12V@100mA -12V@20mA

Let's get started.

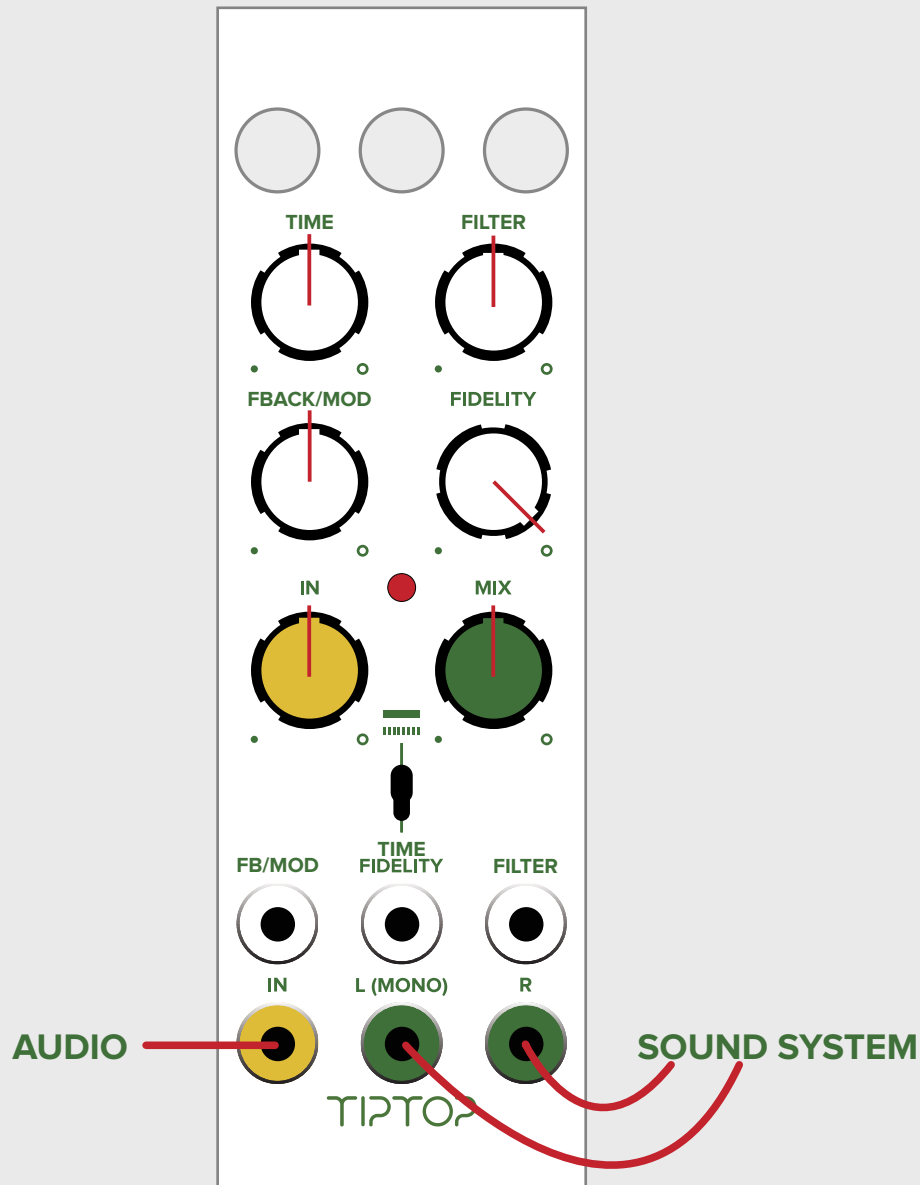

Set the Fidelity to max (CW), turn on power, patch audio into the In jack, patch the left and right output to your sound system. Make sure to patch both left and right so you get the full joy of stereo.

Set the following knobs to the center: MIX, IN, TIME, FILTER, FEEDBACK/MOD.

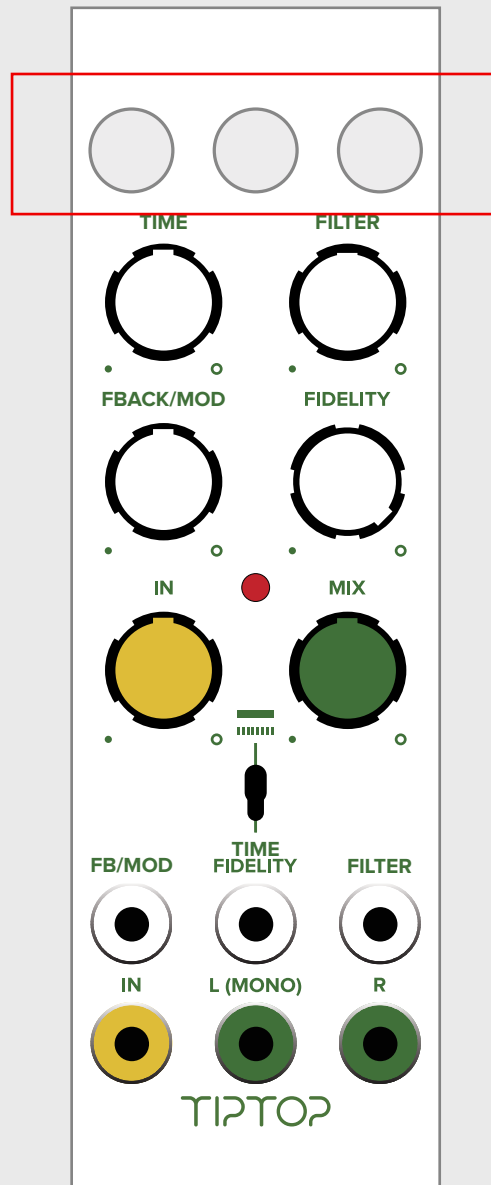

There are 3 buttons on the module, each one lets you scroll through a bank of 8 effects. Hold down the Left button until it flashes indicating it is loading this bank into the DSP. Now that you are in that bank, scroll through the eight effects by clicking the left button. You will notice that everytime you switch a program the light on the 3 buttons indicate a pattern, the pattern is there for 5 seconds and then goes off. This light pattern can help you remember a specific effect you liked. If the pattern light turns off and you would like to view it again just short click one of the other two inactive bank buttons.

1	●	●	●
2	●	●	●
3	●	●	●
4	●	●	●
5	●	●	●
6	●	●	●
7	●	●	●
8	●	●	●

While scrolling, once you reach the YELLOW YELLOW YELLOW pattern you know you are on effect No8, the last effect in that bank. The bank light will also turn red. One more click and you are back to effect No1 RED RED RED. Scrolling will continuously load the effects in a loop 1..2..3.....7..8..1..2..3 etc.

These FX modules were designed on the concept of scrolling and auditioning the effects live. We recommend scrolling while listening and stop on the effect you like. The module will remember which program you last used in a bank so when you switch between banks you can switch between 3 of your favorite effects, one in each bank.

To switch to the next bank, just hold down the next bank button down and a new bank will load up into the DSP.

The Effects Program section for each module has the LED patterns for each effect. It might be useful for the first time using the module to print or look up the table while scrolling to get familiar with the type of effects.

Understanding the view modes:

The module has two different display modes: default and minimal. The differences are listed below:

Default: Shows the program number in binary when changing programs. Also, pressing an inactive bank button shows the current preset number. Consult the charts in the effect programs for the LED combinations for each program. Default also remembers the last program set in each bank, so switching from the left bank to the middle or right bank will load the last used program in that bank. For example, switching from Left bank program 3 to Right bank then back to Left will recall program 3 again.

Minimal: No display of the program number as shown in the effects program section. The bank button will be yellow for programs 1-7 and turn red at program 8. Changing a bank will load program 1 each time. For example, changing from Left bank program 3 to Right will load program 1 in that bank, and switching back to Left will load program 1 again.

If you would like to change the mode:

- To select the minimal mode hold down the center button on power up.
- To select the default mode hold down the right button on power up.

The selected mode is stored in memory and will be recalled on future power ups. We encourage you to try both modes and find the one that is better for you, this is a personal preference.

Manual Controls:

Left Button - Hold to access the Left bank of 8 programs

Middle Button - Hold to access the Middle bank of 8 programs

Right Button - Hold to access the Right bank of 8 programs

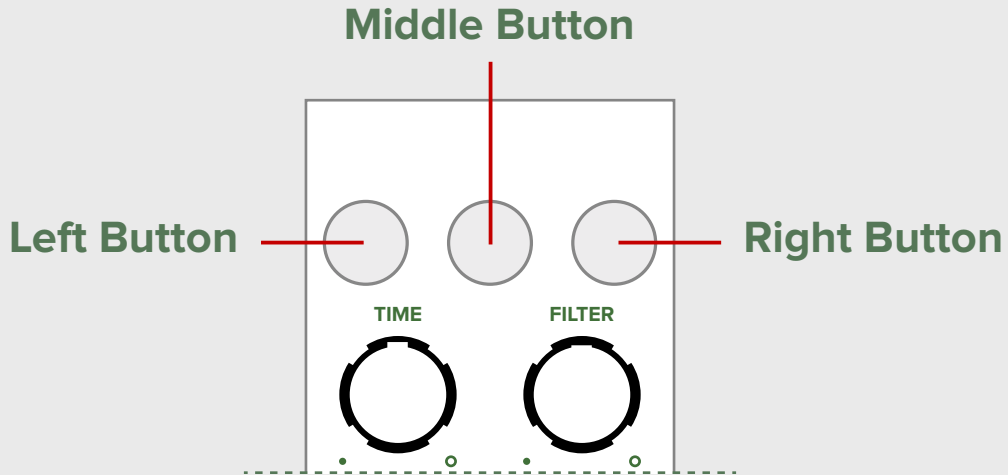

Time knob - controls the decay time of Reverbs, the Delay time or the rate of Modulation LFOs

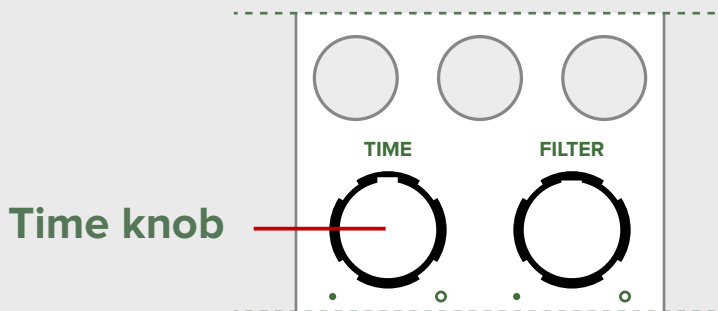

Filter knob - sets the cutoff frequency of the low/high or bandpass filters in the program

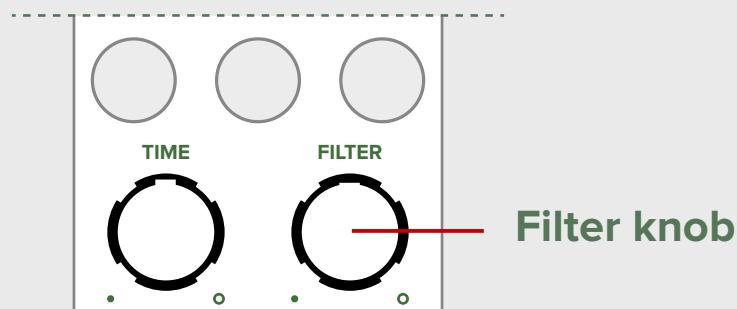

Feedback/Mod knob - changes the amount of feedback in delay programs or the depth/rate of LFOs in Reverb or Mod programs. Check the program descriptions for details on what this controls.

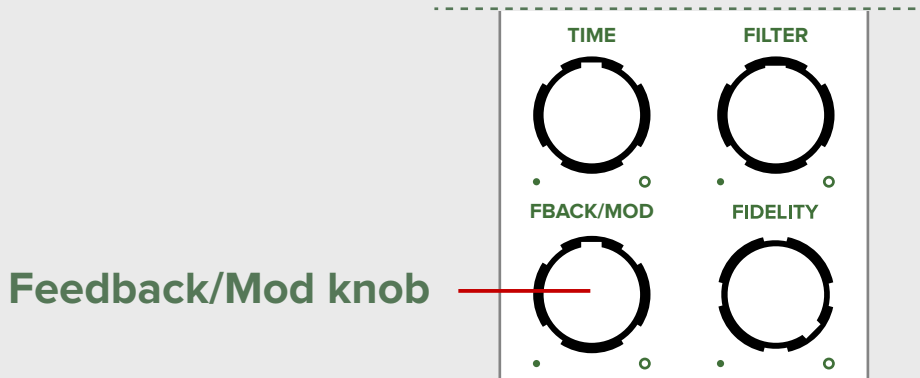

Fidelity - Is a DSP manipulation technique developed originally for the Z-DSP and brought to this line of effect modules as well. Inside the module is an analog VCO that clocks the DSP chip, the use of an analog clock (not a digitally generated clock) not only contributes to the overall organic sound quality of the module, but also lets you take the effects into new sonic territories with variation of the clock speed. The Fidelity knob in will alter the frequency of the VCO clock with sound effects ranging from pitch shifting and down to total degraded digital noise.

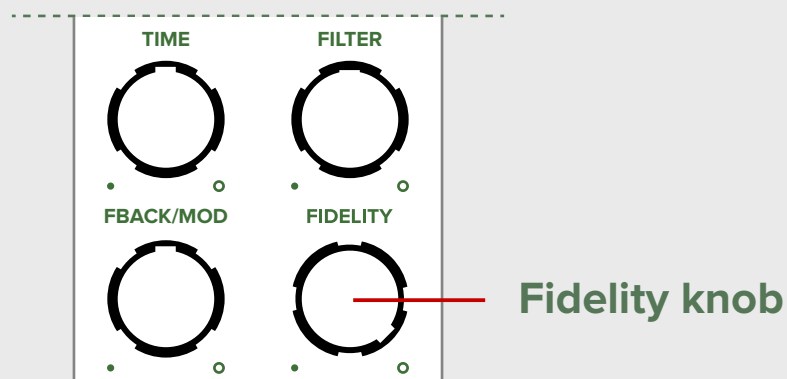

CV Controls:

There are 3 CV control jacks on the module: **Feedback/Mod**, **Time** and **Filter**. The left and right jacks are dedicated for controlling DSP parameters mapped to the Mod and Filter controls, the center jack CV can be routed with the toggle switch to either TIME which is a DSP parameter or to Fidelity clock control.

The DSP CV controls have a built in slew circuit which limit the speed they can be modulated. This is part of the design of the DSP chip. The Fidelity CV is all analog and can be modulated at any speed and even into the audio range.

In extreme cases where negative voltage CV is applied to Fidelity the DSP chip might crash, this does not damage anything, just remove the negative CV, switch a program and the DSP will be back in action.

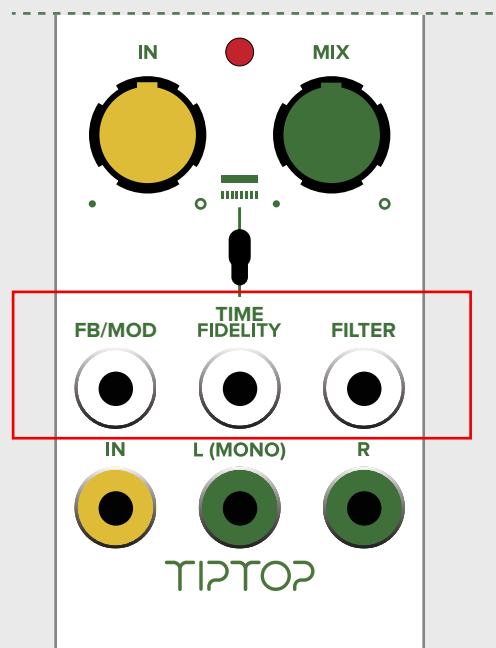

Clipping light indicator:

The clipping light monitors the input and output signal level of the DSP chip. If a signal level at the input or the output is too high that light will flash. Some times due to feedback the output signal can grow much larger than the input signal, in that case reduce the amount of Feedback with the Feedback knob.

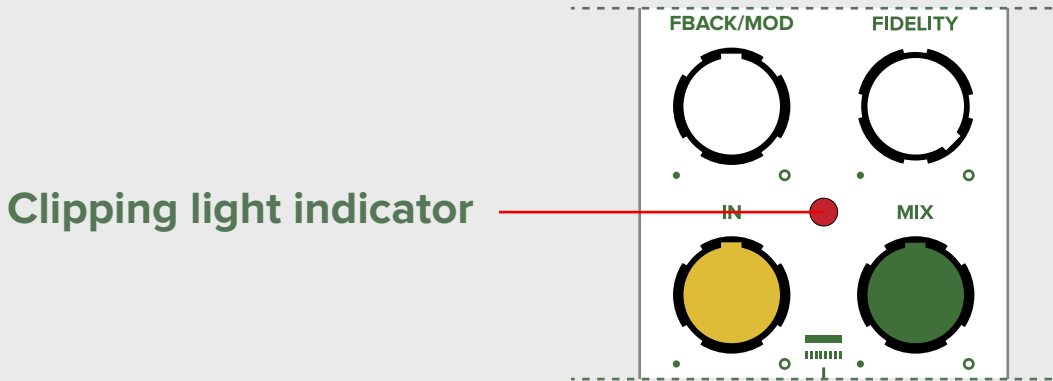

Output gain:

The IN level knob on the FX modules is exponential, which means that from 0 to 50% of the knob rotation the gain setting increases in small amounts letting you carefully set the output gain to Line Level to avoid clipping external audio equipment. From 50 to 100% the gain increases in larger amounts letting you set the outputs to Eurorack levels. This arrangement makes the module output versatile without a need for jumpers to set the volume level.

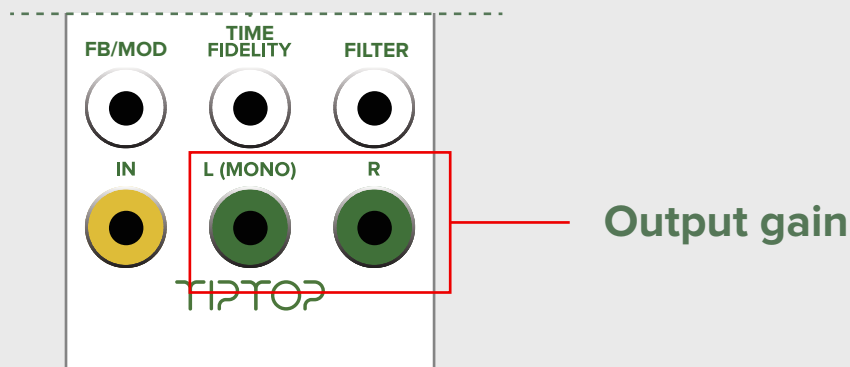

A word about your sound sources:

Every effect reacts differently to the source sound, this can result in some effects sounding very dull or strange if the incoming sound is not ideal for their use.

Later sections of this user manual have detailed description of each effect and the source material that will work with it best. Obviously, these are just recommendations and in the spirit of the modular synthesizer going the 'wrong' way can often lead you to sounds you have never heard before. Experiment!

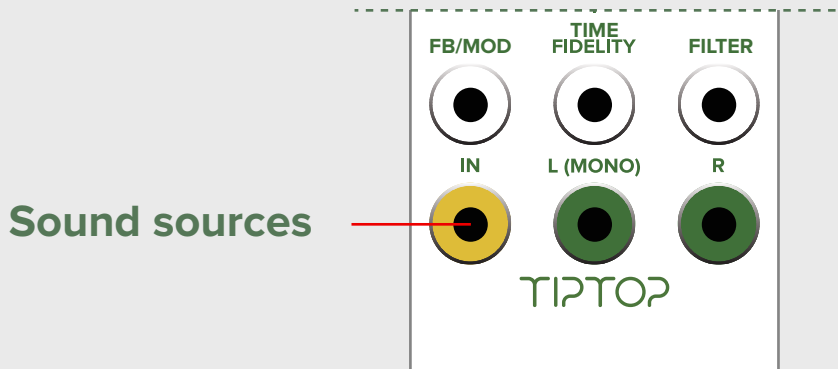

FAQ:

Question: Are the delays on the FX modules syncable to external clock?

Answer: No, the variable clock rate of the DSP chip prevents clock sync programs from syncing precisely.

Question: Is my last selected program saved after I turn off my modular?

Answer: Yes it is.

Question: What is the difference between Time and Fidelity CV?

Answer: The Fidelity control changes the speed of the digital processing sample rate. This can have a similar effect to changing the Time control of delays but the important difference is that Fidelity also changes the entire processing including filter cutoffs, LFO speeds, etc. Lowering Fidelity will increase the delay time of a delay but also lower the cutoff of a low pass filter and slow down an LFO modulating the delay line. The Time control will only change the delay time of that same delay.

Question: What are the differences between these modules and the Z-DSP?

Answer: The Z-DSP has stereo input, VC analog feedback, CV control over more features and a potentially unlimited number of programs through the cards. Z-DSP is more of an effects experimentation environment that you can even write your own effects for using NumberZ.

The Zfx line of modules are designed to add a limited well selected number of useful effects in minimal HP.

	Z-DSP	Zfx
Stereo In	Yes	No
Clock source	Digital or External	Internal Analog
Mix CV	Yes	No
VC Analog Feedback	Yes	No
VC Program switching	Yes	No
Text Display	Yes	No
Card Expansion	Yes	No (24 fixed programs)
Program with NumberZ	Yes	No
Width	28HP	8HP

Specifications:

+12V - 130mA (black panel) 100mA (white panel)

-12V - 20mA

+5V - 0mA

Width - 8HP

Depth - 40 mm /1.5"

CV Range - 0 - 5V

Fidelity CV Range 0 - 5V or +/-2.5V

Input Max before clipping - 12V p-p

Output Max before clipping - 10V p-p

Z5000

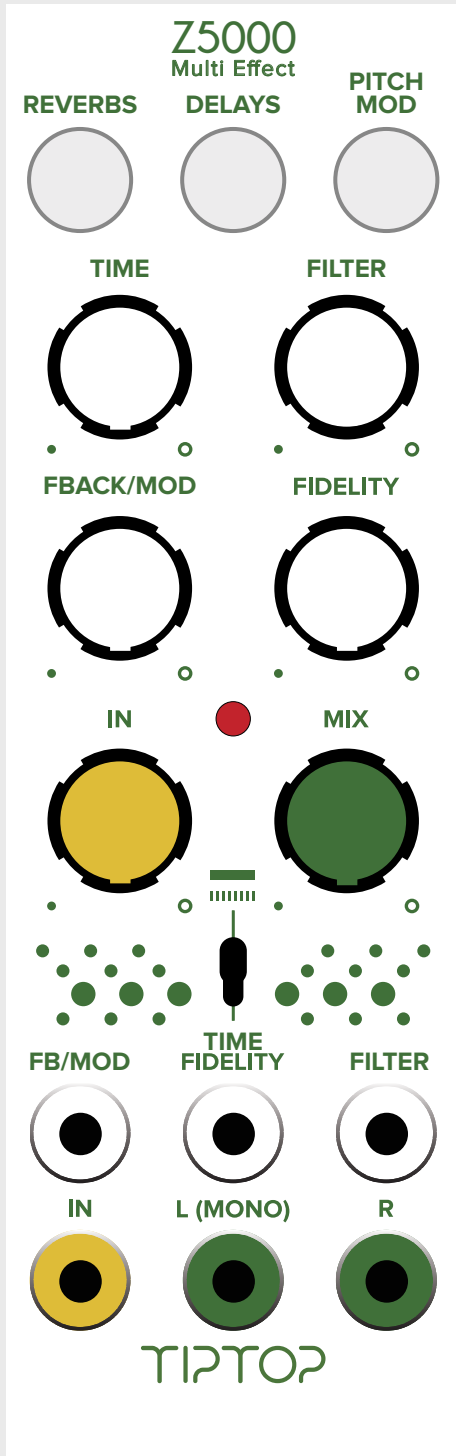

Z5000

REVERB			
Hall			
Plate			
80's Verb			
Gate			
Room			
Void			
Delay > Hall			
Shimmer			

DELAY			
Mono Digital Delay			
Mono Tape Echo			
Ping Pong Digital Delay			
Ping Pong Tape Echo			
Tape Multi-Head Blend			
Diffuse Band Delays			
Tape Chorus			
Warp Pong			

PITCH/MOD			
Stereo Chorus			
Stereo Flanger			
Vintage Ensemble			
Ahhhensemble			
Formant Delay			
Dual Microshift Delay			
Dual Interval Delays			
Detuned Taps			

REVERB PROGRAMS FOR Z5000

Z5000 has a set of reverb algorithms specifically designed for it and the ZVERB module. All of the programs here were developed over several years by Tiptop R&D and take inspiration from the history of digital reverb devices from the earliest 1970s studio rack units to 90s high end multi-effects and 80s budget boxes.

Hall



A version of the classic 70s 'Hall' style reverb. This has a dark, dense yet somewhat 'natural' sound. The Time control is optimized for longer times up to several minutes.

Time - Decay time of the reverb tail

Filter - Low Pass Filter

Mod - Rate of internal modulation

Plate



The sound is brighter than 'Hall' with a faster attack but is also quite dense. With lower Modulation settings a more metallic sound is possible. The Time control is optimized for medium-sized times up to several seconds.

Time - Decay time of the reverb tail

Filter - Low Pass Filter

Mod - Rate and intensity of internal modulation

80s Verb



This one comes from the 80s 'budget' rack units and can get very huge and highly modulated. Probably the best choice for your contribution to 'Selected Ambient Works III'.

Time - Decay time of the reverb tail

Filter - Low Pass Filter

Mod - Rate and intensity of internal modulation

Gate



A gated version of the Plate algorithm. Party like it's 1985!

Time - Decay time of the reverb tail

Filter - Low Pass Filter

Mod - Rate and intensity of internal modulation

Room



Room with early reflections and minimal coloration at low Time settings. Can become decently large with increased Time and the Mod gets very wobbly at high settings just for fun.

Time - Decay time of the reverb tail

Filter - Low Pass Filter

Mod - Rate and intensity of internal modulation

Void



Backwards, inverse sounding effect that gets pretty huge at longer Time settings.

Time - Decay time of the reverb tail

Filter - Low Pass Filter

Mod - Rate and intensity of internal modulation

Delay > Hall



A 500ms modulatable mono delay line feeds into the Hall algorithm. The Feedback/Mod control adjusts the delay time and the Time parameter increases both the delay line feedback and the decay time of the Hall.

Time - Decay time of the reverb tail + delay feedback

Filter - Low Pass Filter

Mod - Delay time + delay feedback

Shimmer



An octave up pitch shifter in the reverb creates the classic 'shimmer' tone. The Feedback/Mod control adjusts how much of the pitch shifted sound is present. Setting the pitch level higher with smaller decay Time settings will increase the pitch level and have it come in sooner. At longer decay Time settings very high pitch level can overload the internal loop and clip the outputs!

Time - Decay time of the reverb tail

Filter - Low Pass Filter

Mod - Amount of octave up pitch shift in the reverb tank

Delay Programs for Z5000

The Z5000 Delay programs come from many years of development of the Z-DSP cards. Most of the programs in this set began life on the Z-DSP and are chosen to give a wide range of options from basic mono digital and tape delays to complex multi-taps.

Mono Digital Delay



Basic mono digital delay line with a low pass filter in the feedback loop. The delay time can be modulated without glitching and produces an FM type effect. At max feedback the sound will loop for a long time but also slightly degrade over time.

Time - delay time

Filter - cutoff of lowpass filter

Feedback - amount of feedback into the delay line

Mono Tape Echo



Mono Tape Echo program with a bandpass filter and tape saturation in the feedback loop. Feedback is also overdriven to get some of the runaway oscillations found in real tape machine echo boxes.

Time - delay time

Filter - cutoff of bandpass filter

Feedback - amount of feedback into the delay line

Ping Pong Digital Delay



Dual delay lines move the delayed sound from left to right and back. A lowpass filter in the feedback path tapers the high end of the repeats.

Time - delay time

Filter - cutoff of lowpass filter

Feedback - amount of feedback into the delay line

Ping Pong Tape Echo



Tape Echo version of a stereo Ping Pong algorithm.

Time - delay time

Filter - cutoff of bandpass filter

Feedback - amount of feedback into the delay line

Tape Multi-Head Blend



Three tape 'heads' each with different delay times feed the Filter blend control. At the center all three taps are mixed in the output while only two are present at the extreme left and right settings. All of the heads heard in the output are fed back.

Time - delay time

Filter - mix of heads 1, 2 and 3. Mid point has all 3

Feedback - amount of feedback into the delay line

Diffuse Band Delays



A delay line with six taps each run through a different band pass filter. The taps are useful rhythmic ratios (1:1, 1:2, 3:4, etc). The feedback loop has diffusion to wash out the repeats over time.

Time - Delay time

Filter - adjusts modulation and diffusion parameters

Feedback - amount of feedback into the delay line

Tape Chorus



A mono Tape Echo feeds a stereo Chorus. The Filter control also changes the rate of the Chorus modulation: lower cutoff is a slower LFO and the speed increases as the filter cutoffs do as well.

Time - delay time

Filter - cutoff of bandpass filter and rate of chorus

Feedback - amount of feedback into the delay line

Warp Pong



A stereo ping pong delay using the Tape Echo algorithm but with a warping to the speed of the tape. The Filter control also influences the warping speed a little bit.

Time - delay time

Filter - cutoff of bandpass filter

Feedback - amount of feedback into the delay line

Pitch/Mod Programs for Z5000

This collection of Pitch and Modulation programs are adapted from years of work on the Z-DSP cards like Chorus, Time Fabric and Spirals with a few new algorithms too.

Stereo Chorus



A pair of Chorus create a stereo effect. Each has a different speed and phase LFO for spacious stereo from a mono source. The high pass filter is useful to pass bass tones unmodified and only process the harmonics.

Time - the rate of the LFOs

Filter - high pass filter

Feedback/Mod - depth of the LFO sweeps

Stereo Flanger



Dual flangers with separate LFOs and a feedback control to inject the output to the input for classic jet plane sounds.

Time - the rate of the LFOs

Filter - amount of feedback. Counter clockwise for negative, clockwise for positive

Feedback/Mod - depth of the LFO sweeps

Vintage Ensemble



An emulation of one of the most famous string synth effects. Use 100% wet for best results. The mix of vibrato can be controlled and about 30% is close to the original circuit. The Time control adds in Octave Up and Down pitches to thicken up the sound. Works best with basic waveforms. Stereo output.

Time - Amount of octave up and down mixed in

Filter - high pass filter

Feedback/Mod - amount of vibrato

Ahhhensemble



Three formant filters create the 'Ahh' vocal sound with control over the center frequency to sweep from male to female formant tones. This is also fed through an ensemble effect. Try with raw saw waves and 100% wet.

Time - the rate of the LFOs

Filter - tuning of the formant filter

Feedback/Mod - depth of the LFO sweeps

Formant Delay



Mono delay lines runs into a Formant filter with 4 vowel sounds. The Filter control selects one of the vowels and the three filters are slightly spread in stereo. The delay feedback is before the filter so setting high levels of feedback will allow modulation of the vowel type as the sound decays.

Time - delay time

Filter - selects one of 4 vowel sounds

Feedback/Mod - amount of feedback

Dual Microshift Delay



Two pitch shifters set to the detune range follow a mono delay line. The pitch shifters are in the feedback path so the detuning can create up/downwards slides.

Time - delay time

Filter - detuning amount for the pitch shifters

Feedback/Mod - amount of feedback into the delay line

Dual Interval Delays



A multi-tap dual delay with two pitch shifters which are tuned to various intervals. The shifters are in the delay line feedback loop to create various pitch arpeggio and glissando type effects.

Interval pairs: -12/+12, -12/-7, -12/-5, -5/+3, -5/+4, +7/+4, +7/+12, +12/+12

Time - delay time

Filter - intervals for the pitch shifters

Feedback/Mod - amount of feedback into the delay line

Detuned Taps



A multitap delay line with a pair of detuned pitch shifters and diffusion. Higher amounts of detuning create up/down glides. Higher feedback amounts add a reverberant wash to the repeats.

Time - delay time

Filter - detuning amount for the pitch shifters

Feedback/Mod - amount of feedback into the delay line

ECHOZ

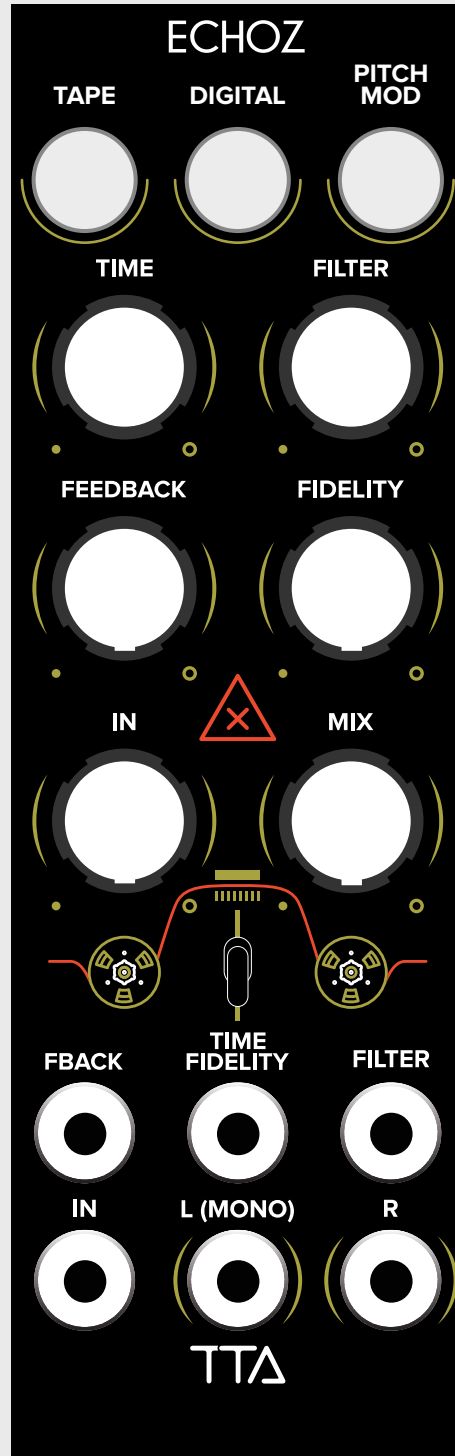
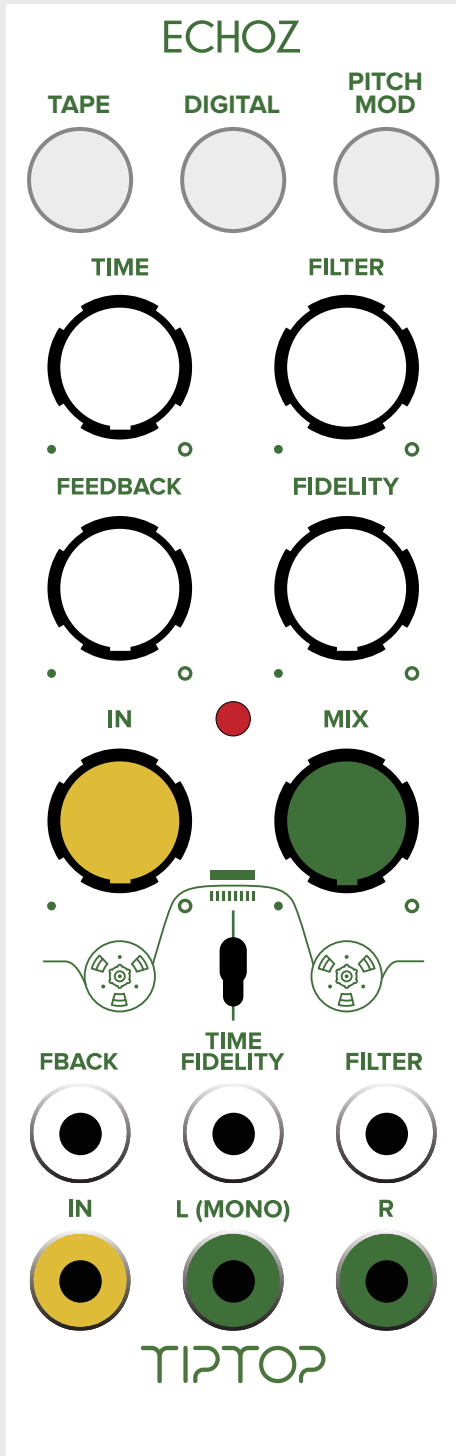

ECHOZ

TAPE ECHO			
Mono Tape Echo			
Ping Pong Tape Echo			
3 Head Mixed Echo			
3 Head Switch Echo			
Chorus Echo			
Diffuse Chorus Echo			
Wobbly Tape Echo			
Warp Pong			

DIGITAL DELAY			
Mono Digital Delay			
Ping Pong Digital Delay			
Short BBD			
Formant Delay			
Dual Ratio Tapped Delay			
Bandpass Tap Select			
Diffuse Delay			
Multi-tap Diff. Band Delays			

PITCH			
Mono Pitch Shift Delay			
Mono Interval Shift Delay			
Chord Delay			
Interval Feedback Loop			
Dual Microshift Delay			
Shimmer Taps			
Diffuse Pitch Band Taps			
Detuned Taps			

EFFECTS PROGRAMS FOR ECHOZ

Tape Echo Programs:

Tape Echo programs use saturation and limiting to emulate the sound of classic tape based echo units. The additional gain in this mode will amplify system noise especially at high feedback levels. This noise is integral to the tape sound.

Tape Echo has a dual low pass and high pass filter configuration that moves between low pass at full counter-clockwise through bandpass to full high pass at full clockwise position.

Mono Tape Echo



This is a single head style tape echo with mono output similar to the earliest tape units. The maximum delay time is tuned for shorter rhythmic, slapback and associated effects.

Time - delay time

Filter - cutoff of bandpass filter

Feedback - amount of feedback into the delay line

Ping Pong Tape Echo



A pair of delays where the input feeds the left channel and the output of the left delay feeds the input of the right delay. The feedback is taken from the output of the right side. Both delays have the same delay time for easy rhythmic effects.

Time - delay time

Filter - cutoff of bandpass filter

Feedback - amount of feedback into the delay line

3 Head Mixed Echo



A three head Echo in the style of some famous 70s units. The three heads are continuously blended between using the Filter control. The output is stereo.

Time - delay time

Filter - cutoff of bandpass filter and mix of three heads

Feedback - amount of feedback into the delay line

3 Head Switch Echo



The Filter control also switches between combinations of the 3 heads (1+2, 1+3, 2+3, 1+2+3). Note that there may be slight jumps in the sound when switching. Stereo output.

Time - delay time

Filter - cutoff of bandpass filter and switching between heads

Feedback - amount of feedback into the delay line

Chorus Echo



Like the Mono Echo in program 1, but with a stereo Chorus after the delay. The speed of the Chorus increases as the Filter control moves to high pass.

Time - delay time

Filter - cutoff of bandpass filter and chorus rate

Feedback - amount of feedback into the delay line

Diffuse Chorus Echo



Adds Diffusion to the input and echo repeats creating more of a detuned wash to the sound. The diffusion is modulated by internal LFOs for detuning/chorusing and the output is in stereo.

Time - delay time

Filter - cutoff of bandpass filter

Feedback - amount of feedback into the delay line

Wobbly Tape Echo



An internal LFO modulates the delay time slightly to give some wobble chorus/vibrato to the sound. The modulation rate is tied to the Filter control and speeds up as the filter cutoff increases. Both the Feedback amount and Delay time influence the depth of the wobble: High feedback increases the wobble effect as does shorter delay times. Mono output.

Time - delay time

Filter - cutoff of bandpass filter

Feedback - amount of feedback into the delay line

Warp Pong



Stereo Ping Pong delays with internal LFOs modulating the delay time. Each side has a different modulation rate that increases as the Filter control is raised. Feedback and delay Time also change the depth of the modulation. Stereo output.

Time - delay time

Filter - cutoff of bandpass filter

Feedback - amount of feedback into the delay line

Digital Delay Programs:

Digital Delay programs use a single mono, dual or multi-tap stereo algorithms. The delay line reads are interpolated to minimize distortion from modulation and also provides pitch bending effects.

Mono Digital Delay



A simple mono delay line with a low pass filter in the feedback path to roll off the high end of repeats. This program has the longest single delay time of any ECHOZ programs.

Time - delay time

Filter - cutoff of low pass filter

Feedback - amount of feedback into the delay line

Ping Pong Digital Delay



Two delay lines, Left and Right. Input enters the Left delay line and is output to the Left output and also the input of the Right delay line. The output of the Right delay line is fed back into the Left input. The effect is the echo bouncing from Left to Right and back again.

Time - delay time

Filter - cutoff of low pass filter

Feedback - amount of feedback into the delay line

Short BBD



A very short mono delay that emulates early analog 'bucket brigade delays' (BBD). This program is designed for short flange, chorus, slapback and Karplus-Strong effects. The latter is achieved by turning up the feedback to a high level and using the delay time to set the pitch of the string pluck. Use short percussive sounds (or triggers) to excite the delay line and try it with Vocals too.

Time - delay time

Filter - cutoff of low pass filter

Feedback - amount of feedback into the delay line

Formant Delay



Mono delay lines runs into a Formant filter with 4 vowel sounds. The Filter control selects one of the vowels. The delay feedback is before the filter so setting high levels of feedback will allow modulation of the vowel type as the sound decays. Stereo out.

Time - delay time

Filter - selects one of 4 vowel sounds

Feedback/Mod - amount of feedback

Dual Ratio Tapped Delay



A dual tap delay line with 1.0x, 0.75x, 0.5x, 0.375x and 0.25x delay time taps. The filter control selects from the following 8 combinations:

1.0	0.75
1.0	0.5
1.0	0.375
1.0	0.25
0.75	0.375
0.75	0.5
0.5	0.375
0.375	0.25

Time - delay time

Filter - selects the combination of heads

Feedback/Mod - amount of feedback

Bandpass Tap Select



A multi-tap delay line with 1.0x, 0.75x, 0.5x, 0.375x delay time taps. Each tap has a bandpass filter. The Filter control selects which of the taps is used for feedback.

Time - delay time

Filter - selects one of the taps for the feedback loop

Feedback/Mod - amount of feedback

Diffuse Delay



A single mono delay line with stereo diffusion creates a reverberant wash as the repeats decay.

Time - delay time

Filter - cutoff of low pass filter

Feedback - amount of feedback into the delay line

Multi-tap Diffuse Band Delays



Multi-tap bandpassed delay with diffusion in the feedback path. Low feedback settings produce a rhythmic effect and increasing feedback turns into a more reverb like sound. The Filter control increases the modulation of diffusion so higher levels reduce the ringing of the delay feedback but can also introduce vibrato to pitched sounds.

Time - delay time

Filter - rate of modulation of the diffusion

Feedback - amount of feedback into the delay line

Pitch Programs:

Pitch programs on ECHOZ have one or two pitch shifters along with single or multi-tap delay lines. Interval programs have the pitch of the shift quantized to musical values (third, fifth, octave, etc) while the others have shifts that range from octave down to octave up or 'microshifts' with subtle detuning. Some of the programs have the pitch shifting in the feedback loop to create up and down arpeggio or glissando type effects.

Mono Pitch Shift Delay



A mono delay line into a single pitch shifter. The pitch shift is not quantized to intervals and has a range of -1 octave to +1 octave (-1200 to +1200 cents). Pitch shifting is after the delay feedback so the pitch is constant as the repeats decay.

Time - delay time

Filter - Pitch shift amount from -1200 to +1200 cents

Feedback - amount of feedback into the delay line

Yellow_Red_Red

Mono Interval Shift Delay



A mono delay line into a single pitch shifter. Pitch shifting is after the delay feedback so the pitch is constant as the repeats decay. The pitch shift is quantized to the 8 intervals listed below:

-12 -7 -5 -3 +3 +4 +7 +12

Time - delay time

Filter - selects interval

Feedback - amount of feedback into the delay line

Chord Delay



A mono delay line into a pair of pitch shifters panned left and right. Pitch shifting is after the delay feedback so the pitch is constant as the repeats decay. The pitch shift is quantized to the 8 intervals listed below:

-12 +12
-12 -7
-12 -5
-5 +3
-5 +4
+4 +7
+7 +12
+12 +12 (detuned)

Time - delay time

Filter - selects interval

Feedback - amount of feedback into the delay line

Interval Feedback Loop



A mono delay line into a pair of pitch shifters panned left and right. Pitch shifting is inside the delay feedback so the pitch moves up or down as the repeats decay forming arpeggio patterns. The pitch shift is quantized to the 8 intervals listed below:

-12 +12
-12 -7
-12 -5
-5 +3
-5 +4
+4 +7
+7 +12
+12 +12 (detuned)

Time - delay time

Filter - selects interval

Feedback - amount of feedback into the delay line

Dual Microshift Delay



A mono delay line into a pair of micro pitch shifters. The pitch shifting is fixed to a slight detune on one side and small shift up on the other. The Filter control blends between the two with all the way counter-clockwise being only downward to only upward shift on the full clockwise. Both pitch shifters are in the feedback path so the pitch will continue to rise or drop as the repeats decay.

Time - delay time

Filter - Mix of downward (CCW) to upward (CW) tuning

Feedback - amount of feedback into the delay line

Shimmer Taps



Multi-tap delay with a single octave up pitch shifter. Based on the classic reverb 'Shimmer' effect the octave effect is in the feedback loop of the delay. The Filter control sets the amount of pitch shift in the feedback and combined with the Feedback control allows for a variable mix of delay and pitch shift.

Time - delay time

Filter - Amount of pitch shift in the feedback loop

Feedback - amount of feedback into the delay line

Diffuse Pitch Band Taps



Multi-tap delay with a single variable pitch shifter. The taps have both diffusion and bandpass filters. Pitch shifting is not in the feedback path so the pitch remains constant as the repeats decay.

Time - delay time

Filter - Pitch shift amount from -1200 to +1200 cents

Feedback - amount of feedback into the delay line

Detuned Taps



A multitap delay line with a pair of detuned pitch shifters and diffusion. Higher amounts of detuning create up/down glides. Higher feedback amounts add a reverberant wash to the repeats.

Time - delay time

Filter - detuning amount for the pitch shifters

Feedback/Mod - amount of feedback into the delay line

ZVERB

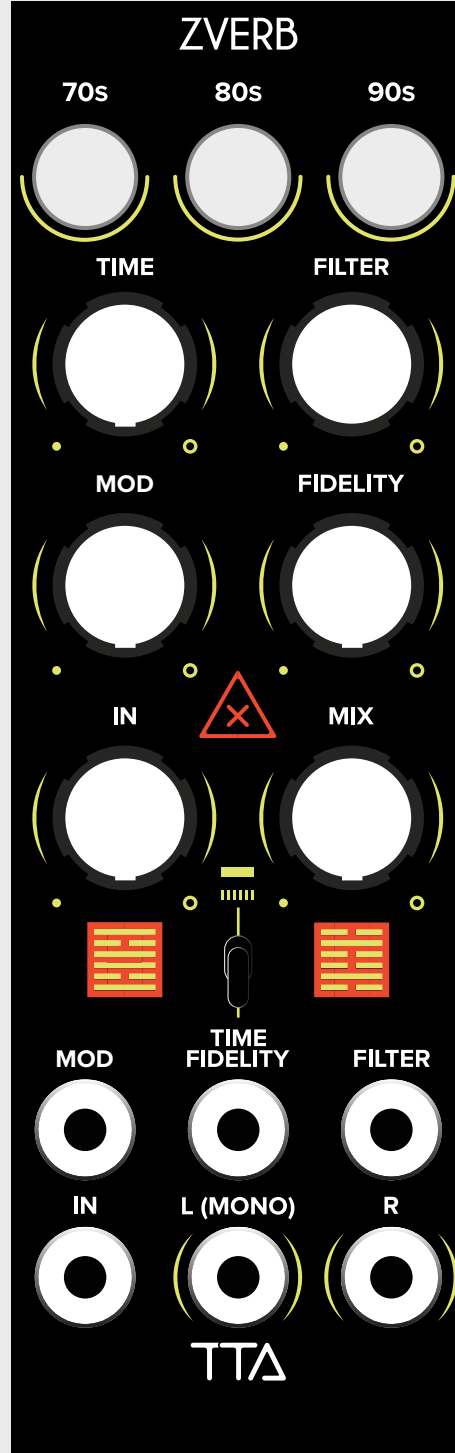
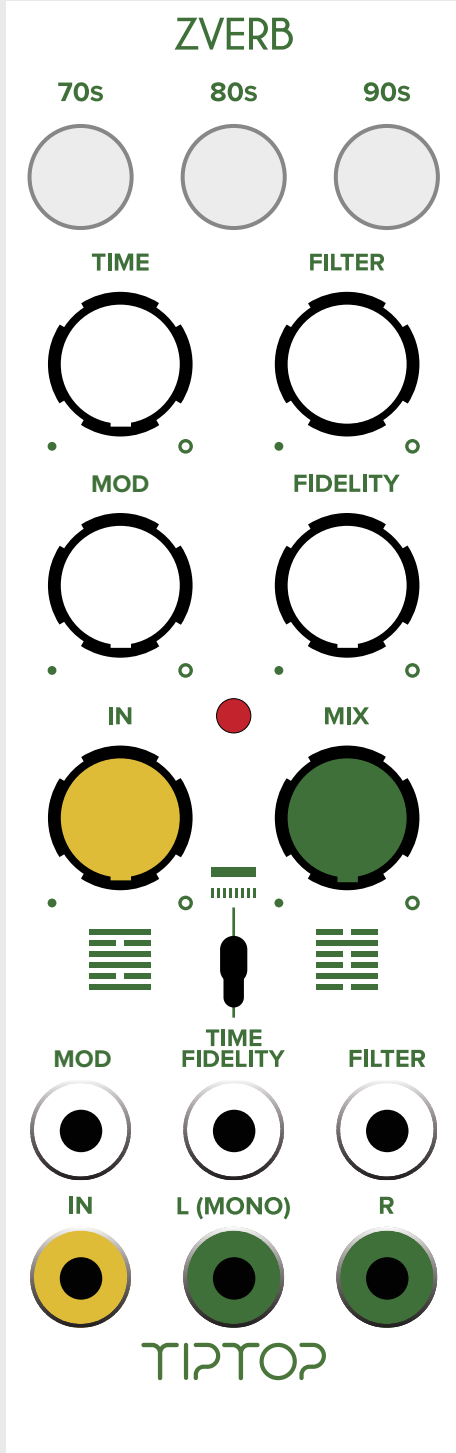

ZVERB

70s			
Hall			
Plate			
Bright Plate			
Tape > Plate			
Earliest 'Verb			
Space Station			
Prehistoric Exhibit A			
Epic Mod Hall			

80s			
80s BarrVerb			
Ambience			
Gated			
Delay > Hall			
Shimmer Octave Up/Down			
Shimmer Pitch Adjust			
Blooming			
Pitch over Plate			

90s			
Room			
Void			
Downward Spiral			
Random Hall			
Pong Verb			
ChordHall			
Pitch > Chorus			
Formant Verb			

EFFECTS PROGRAMS FOR ZVERB

ZVERB is based on the same audio DSP technology as the Z-DSP multi-effects module and benefit from nearly a decade of experience designing algorithms for it. Tiptop R&D developed all of the programs on ZVERB in house over several years. These algorithms are inspired by some of the most important digital reverb devices since the late 1970s, from very high end studio devices to low cost 1U rack units for home studios and touring musicians.

70s Programs:

The 1970s saw the introduction of programmable digital technology to the audio industry. The first half of the decade featured primitive delays followed by the first pitch shifters, but by the late 70s enough processing power and memory was available to do algorithmic reverb (and other effects). This bank features interpretations (not emulations or clones) of the first generation of digital reverb.

Hall



A version of the classic 70s 'Hall' style reverb. This has a dark, dense yet clear sound. The Time control is optimized for longer times up to several minutes.

Time - Decay size of the space

Filter - Low Pass Filter

Mod - no function

Plate



The sound is brighter than 'Hall' with a faster attack but is also quite dense. With lower Modulation settings a more metallic sound is possible. The Time control is optimized for medium-sized times up to several seconds.

Time - Decay size of the space

Filter - Low Pass Filter

Mod - Rate and intensity of internal modulation

Bright Plate



Like the previous Plate program but with a high pass filter and tuned for a shorter and brighter sound overall.

Time - Decay size of the space

Filter - High Pass Filter

Mod - Rate and intensity of internal modulation

Tape > Plate



A mono tape echo is placed before the Plate algorithm. The echo has saturation and limiting plus a bandpass filter which can give some crunchy sounds to feed into the plate. The Mod delay time and Time reverb decay also control the tape echo feedback - increasing those controls feeds more back into the echo.

Time - Decay time of the space + echo feedback

Filter - Bandpass Filter

Mod - Tape Echo head delay time + echo feedback

Earliest 'Verb



Based very loosely on the first commercial reverb box. The Mod control changes the 'Size' of the reverb which is not the same as changing the Decay Time control. This has a smaller overall size than the Hall.

Time - Decay time of the space

Filter - Low Pass Filter

Mod - Size of the space

Space Station



What? This isn't a 'reverb at all! True, this algorithm is a multi-tap delay based on a very early digital processor called the Ursa Major Space Station. The Mod control changes the taps used in the output and feedback. Filter adjusts an independent mono 'Echo' delay that also factors into the feedback. Try it on percussive tracks and loops, crank the feedback and sync the taps and echo for some robotic rhythm effects.

Time - Feedback

Filter - time of Echo channel delay

Mod - Tap selection

Prehistoric Exhibit A



As the name suggests, this predates any commercial products by many years, but the algorithm was a starting point for all research into artificial digital reverberation. The space is small and can be quite ringy with low Mod settings, but crank up Mod and it becomes quite chorused.

Time - Decay size of the space

Filter - Low Pass Filter

Mod - Rate of internal modulation

Epic Mod Hall



This is the largest of all algorithms in ZVERB and at maximum Time settings it becomes practically infinite. Based on the Hall program but with much higher and adjustable modulation amounts.

Time - Decay size of the space

Filter - Low Pass Filter

Mod - Modulation

80s Programs:

Digital technology hit every part of life in the 1980s and the audio field was no exception from samplers and recorders to a quickly expanding range of effects processors. For the first time 'budget' products put reverb and other effects in the hands of home and touring musicians. The 80s bank of ZVERB features some of the important and iconic algorithms of the decade.

80s BarrVerb



Based on the design of 80s lower cost multi-effects units. This has a simpler structure than the 'Hall' or 'Plate' algorithms but it still creates a very spacious and rich sound. The sound of the internal delays are more prominent than the 70s algorithms. The Mod parameter controls the overall delay length and creates a longer but more obvious echo effect as it increases. The modulation is high and the Time control is tilted to very long and large spaces up to about a minute in time.

Time - Decay size of the space

Filter - Low Pass Filter

Mod - Length of internal delay loop

Ambience



A small space that can go from phone booth to living room to long hallway or city alley in size. The Mod parameter sets the basic size of the space and the Time adds more depth to the decay.

Time - Decay size of the space

Filter - Low Pass Filter

Mod - Pre-delay and Early Reflections scaling

Gated



A Gated Reverb based on a Plate algorithm popular on percussion in the 80s (the button says 80s for a reason!). The Gate follows the input signal and has a quick, clean attack and release. The Fidelity control does slow down the envelope as well as the onset of the reverb.

Time - Decay size of the space

Filter - Low Pass Filter

Mod - Rate and intensity of internal modulation

Delay > Hall



A multi-effect mono delay line into a modulated Hall reverb. The delay line can be modulated with CV for additional echo effects before hitting the reverb. The feedback of the delay line increases with both delay time and reverb decay time controls.

Time - Decay size of the space. Delay feedback

Filter - Low Pass Filter

Mod - Delay time and feedback

Shimmer Octave Up/Down



Dual pitch shifters tuned one octave down (-12 semitones) and one octave up (+12 semitones) are inside the Hall delay algorithm. The Mod control adjusts how much of octave up or down is present in the sound.

Time - Decay size of the space

Filter - Low Pass Filter

Mod - Mix of octave up and down pitch shifters

Shimmer Pitch Adjust



A single pitch shifter with a range from one octave down (-12 semitones) to one octave up (+12 semitones) is inside a modulated Hall algorithm. The Mod control sets the pitch and the Filter control adjusts how much of the pitch shift is added to the reverb decay.

Time - Decay size of the space

Filter - Amount of pitch shift added to reverb

Mod - Pitch of shifter

Blooming



Another one inspired by a very popular 80s budget box. This is really just a set of delays set up to sound 'reverse'. At low Mod and Time settings it recreates the classic inside out sound while increasing those controls brings in a more wobbly wash. It likes to be fed sounds with slightly percussive attacks and solid pitch (ahem, guitar).

Time - Decay size of the space

Filter - Low Pass Filter

Mod - Rate and intensity of internal modulation

Pitch over Plate



A pair of pitch shifters on the output of the Plate program add some weight or air to the reverb tone. The shifters are not in the reverb tank so the pitch is stable and quantized to four intervals: -12, -7, +7 and +12. This one works quite well with percussive sounds as well as pitched ones.

Time - Decay size of the space

Filter - Amount of pitch shift added to reverb

Mod - Pitch of shifter

90s Programs:

Processing power increased and the size of electronics decreased in the 90s giving both much more advanced high end devices and more affordable low cost units. This bank focuses on some of the higher end algorithms of the era which have interesting combinations of delay, pitch, modulation and reverb.

Room



A 'Room' type algorithm that uses a multiple delay line structure popularized in the 90s. At short Times with low modulation this can have a sharp ringing sound like a tiled room and increasing the Time and Modulation will result in denser and more chorused spaces.

Time - Decay size of the space

Filter - Low Pass Filter

Mod - Rate and intensity of internal modulation

Void



Very different design from the other algorithms, this idea originated in high end rack units from the 90s and continues to be very popular in the 21st century. At lower Time settings it almost has a reverse sounding response, while increasing the Time and Modulation creates a very unnatural but lush sound.

Time - Decay size of the space

Filter - Low Pass Filter

Mod - Rate and intensity of internal modulation

Downward Spiral



Based on the previous 'Void' algorithm but with a pair of slightly detuned pitch shifters inside the reverb. The Mod control sets how much detuning and thus how quickly the pitch of the decay spirals down. Also, apparently the title of a popular record of the decade - who knew?

Time - Decay size of the space

Filter - Low Pass Filter

Mod - Rate the pitch spirals down

Random Hall



Based on the Hall algorithm but with lots of randomization inside the reverb. At low Mod settings this makes a nice way to break up the decay of percussive sounds, while higher settings and longer decays will start to wobble pitched instruments quite noticeably.

Time - Decay size of the space.

Filter - Low Pass Filter

Mod - Amount of Randomization of internal parameters

Pong Verb



A set of multi-tap delays fed through diffusion. The taps 'ping-pong' left to right. At low Decay settings and longer Mod delay times the effect is like a stutter. Longer Decay times start to create a reverberant wash that can sometimes sound almost backwards.

Time - Decay time of the space

Filter - Low Pass Filter

Mod - Delay time of each tap

ChordHall



A pair of pitch shifters with 4 sets of intervals run into a modulated Hall algorithm. The pitch effect is not in the decay of the reverb so the pitch remains stable. Good for making tritone chords from mono oscillators.

Time - Decay size of the space

Filter - Low pass filter

Mod - Intervals of pitch shifters:

-12 -5

-5 +3

+4 +7

+7 +12

Pitch > Chorus



A mono delay into single pitch shifter into stereo chorus with diffusion makes for an unconventional reverb effect inspired by a high end 90s rack unit. The delay, pitch shift and chorus are all in the complex feedback path so the pitch will glide up or down as the decay increases. Pitch is unquantized from one octave down (-1200 cents) to one octave up (+1200 cents). Works best with pitched sounds with slow attacks like pads.

Time - Decay time of the space

Filter - Pitch shift from -1200 to +1200 cents

Mod - Delay time of each tap

Formant Verb



A set of bandpass filters create an 'Ahhhh' sound that feeds a Hall type reverb. The Tune control moves the center frequency of the filters from male to female ranges.

Time - Decay time of the space

Filter - Center frequency of formant filters

Mod - No function

TIPTOP audio®